

# RADIO PROGRESS

December 1, 1924  
15 Cents a Copy

Reg. U. S. Pat. Off.

*'Always Abreast  
of the Times''*

## IN THIS ISSUE:

Using Loop or Outside Aerial

Special Article by H. V. S. Taylor

Putting Quality Into Waves

Tracing Signals Through Regenoflex

Do We Want Resistance or Not?

Killing Losses in Condensers

---

*WATCH FOR HOOK-UP NUMBER*

---

YOU WILL UNDERSTAND THIS  
MAGAZINE---AND WILL LIKE IT

*PUBLISHED TWICE A MONTH*

**Here's a Chance to Get Business !**

**TO RADIO DEALERS**  
**AND MANUFACTURERS**

In response to many requests Radio Progress  
will issue a

*Special Hook-up Number*

**TO COME OUT IN THE NEAR FUTURE**

This is a carefully selected list of sets which WILL WORK. They include the best hook-ups of Crystal Sets, Single Tubes, Regenerative and Non-Regenerative, Two and Three-tube Radios, Reflexes, Neutrodynes and Superheterodynes.

This issue is bound to create a demand for parts and sets. You should get some of this business.

Rate card sent on request.

---

***Radio Progress***

***8 Temple Street***

***Providence, R. I.***

***P. O. Box 728***

# RADIO PROGRESS

## SPECIAL HOOK-UP NUMBER

TO BE ISSUED SOON

---

### 15 Worthwhile Hook-ups

---

Undoubtedly you have tried following various wiring diagrams and found that they were not what they pretended to be. This will be a carefully selected list of sets which do work. They include the best hook-ups of crystal sets, single tubes, regenerative and non-regenerative, two and three tube radios, reflexes and also the more ambitious styles, like neutrodyne and superheterodyne.

Among them you will find several, anyway, which you will wish to try out.

---

*Watch For This Issue*

---

# RADIO PROGRESS

HORACE V. S. TAYLOR, EDITOR

Volume 1

Number 18

## *Contents for*

### *DECEMBER 1, 1924*

	Page
USING LOOP OR OUTSIDE AERIAL.....	5
PORTRAITS OF POPULAR PERFORMERS.....	8
PUTTING QUALITY INTO WAVES.....	9
TRACING SIGNALS THROUGH REGENOFLEX.....	13
DO WE WANT RESISTANCE OR NOT?.....	15
AMERICAN RADIO RELAY LEAGUE.....	18
KILLING LOSSES IN CONDENSERS.....	19
EDITOR'S LOUD SPEAKER:	
TRACING A HARD ONE.....	23
MOSTLY ALL BOSH.....	24
A "MIKE" THAT WILL NOT WAIT.....	25
MAKING A GOOD OPERATOR.....	26
SENDING STATION STORIES.....	27
NEW PRODUCTS OF UNUSUAL INTEREST.....	28
DR. RADIO PRESCRIBES.....	29
UNITED STATES BROADCASTING STATIONS.....	31

RADIO PROGRESS is issued on the 1st and 15th of each month by the Oxford Press at 8 Temple Street, Providence, Rhode Island. John F. O'Hara, Publisher. Yearly subscription in U. S. A., \$3.00. Outside U. S. A., \$3.50. Single copies, 15 cents. Entered as second-class matter, April 4, 1924, at the Post Office at Providence, R. I., under the Act of March 3, 1879. Address all communications to RADIO PROGRESS, 8 Temple Street (P. O. Box 728), Providence, R. I. Title registered at United States Patent Office.

The publishers of this magazine disclaim all responsibility for opinions or statements of contributors which may at any time become subjects of controversy.



# GOOD THINGS COMING

## DECEMBER 15th

Do you think the shape of a horn makes any difference in a loud speaker? As a matter of fact it does, and the reason why, together with other interesting points about this unit, are explained in **"Modern Loud Speaker Designs,"** by Smith, in our next issue.

Have you ever had company come and then found that your battery was dead, although the hydrometer shows it half full? In **"No Dead Batteries with This Meter"** Vance explains why this sometimes happens and describes an instrument which prevents such an annoyance.

Dr. Goldsmith contributes a most interesting article. It is called, **"Wedding of Phonograph and Radio."** It points out some of the big differences necessary in building these two seemingly similar music makers. Don't miss it.

Of course you know that the Government licenses all radio stations. Were you aware that their radio inspector prevented some conditions which might cause loss of life? If not, you will want to read the report of Commissioner D. B. Carson, **"U. S. Radio Inspectors Protect You."**

What kind of radio do you want to buy? There are so many good ones on the market that it is difficult to select one. Even if you have two for trial at your home, it is hard to change over from one to the other fast enough so that a real comparison can be made. **"How to Compare Two Radios,"** by Langley, will show you the best way to pick the winner.

Can you tune out your local station and get 3000 miles? Many a set could be improved in its selectivity if you only knew how to go about it. **"What Causes Sharp Tuning?"** by Taylor, shows the causes as well as the means for accomplishing this.

In these days the sending aerial is not necessarily in the same building as the broadcasting studio. Usually, however, it is in the same town. Did you know that one broadcaster located his main studio 100 miles away from his transmitter? See **"Talking 100 Miles to a Studio"** in the December 15 issue.

## Can It Say S S S S S S ?

Most loud speakers cannot say the letter "S," although it is usually not their fault. Often the trouble lies in the audio transformer, which distorts the high notes which appear in the sound. Of course, they distort music the same way, but you are not so apt to notice it.

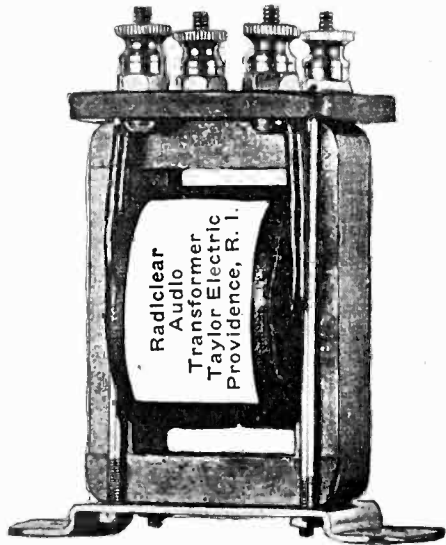

A transformer which pronounces "S" must be a good one. The RADICLEAR will do that very thing. That is one reason why fans say, "You can understand the words." Owing to the large number of turns wound on the core the amplification is unusually great.

It looks good. With its polished bakelite top and nickle-plated base it makes a good appearance and adds to the beauty of any set. If you compare it by hooking it up you will think the price should be \$7.00. However, we will send you one postpaid, for \$3.95. If you are not satisfied, we will refund your money on its return.

## From Atlantic to Pacific

Many people ask us if it pays to try to sell a crystal to people out-of-town.

Our answer is that we are selling the Audion Crystal all over the United States. Orders coming in from the Pacific Coast mix with those from New England.

Although we give money-back guarantee with each crystal, we got only two complaints last month, and neither one called for the money, but for a replacement crystal. Users tell us that the Audion Crystal gives the loudest and clearest reception of any mineral when used within ten to twenty miles of a broadcast station. Besides this, the surface is alive all over. There is no fishing for a sensitive spot. The price is 25c postpaid. Send stamps or coin.

A fit companion for this excellent crystal is our Gold Plated Cat Whisker, which costs 15c. Of course, there is not much gold on it, but there is enough to cover the surface and prevent the wire from tarnishing. More than that is unnecessary.

Sit down now and order an Audion Crystal and Cat Whisker.

# TAYLOR ELECTRIC CO.

1206 BROAD STREET  
PROVIDENCE, R. I.

# RADIO PROGRESS

"ALWAYS ABREAST OF THE TIMES"

Vol. 1, No. 18

DECEMBER 1, 1924

15c PER COPY, \$3 PER YEAR

## Using Loop or Outside Aerial

*Sometimes It Is Well to Change  
From One Kind to the Other*

By HORACE V. S. TAYLOR

**D**OES your set use a loop or outside aerial, or both? That is a question often being asked the radio fan these days. Sets which can use either one or the other are sometimes preferred over those which can not make such a change.

Perhaps it will be interesting to compare the two types and see the advantages, which one may have over the other.

To start with, the most obvious point is one of size. The outside aerial picks up a great deal more energy than the loop, because it is a great deal bigger. It is foolish to think you can carry as much in a pint bottle as is possible in a ten gallon can. The same thing ap-

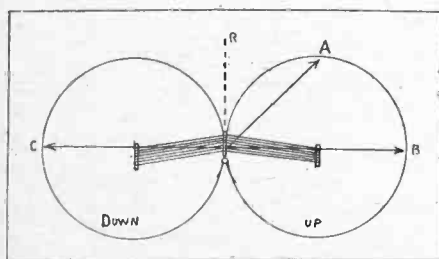

Fig. 1. A Loop Knows Directions

plies in comparing a loop, which may be two feet square, with a wire which reaches up into the air, perhaps twenty-five or thirty feet, and then runs along for fifty to 100 feet. If you should construct a loop with the same dimensions as these you would find that the amount of energy brought in would be about the same.

### Loop Has Sense of Direction

The big advantages which this form of aerial enjoys are first the small size, and

second its sense of direction. Since it is so small, it can be easily carried from room to room, and indeed can be taken with you on your vacation without any trouble. If you wish to loan your set to a friend some evening for a dance, the whole thing can be easily loaded into the back of your machine. This is a good point and influences many people to try out a loop set in their homes, since all the demonstrator has to do is to bring in the equipment and put it on the table. The second advantage, that of knowing which direction a program comes from, has often been mentioned.

To be exact we should not say "which direction" since the loop can tell the general line, but does not know which end of the line is sending. For instance, suppose the sending station is located due north of you. The loop will be able to ascertain that it lies in a north and south line, but whether the waves come from the north or from the south cannot be told. This property of the loop is made use of by the radio inspectors when they go around to locate some source of interference.

### Finding the Interference.

Perhaps some one near you is sending out code during the silent hours from 8 to 10:30. If this is reported and a radio inspector sets out to locate the offending station, which has not given its call letters, he will use a loop. By mounting this on an automobile and listening in, he finds that the station lies in a certain line, as say east and west from where he is at the moment. He pulls out a map and draws a line

through the spot. Then he goes to some other place perhaps half a mile away from that line, and listens again. This time he hears it in a new direction. He draws another line on the map to correspond. These two lines will meet somewhere, and at the intersection he will find the offending source of trouble.

The way a loop receives is shown in Fig. 1. In the center of the picture you will see a top view of the loop itself, looking down on it from above. The

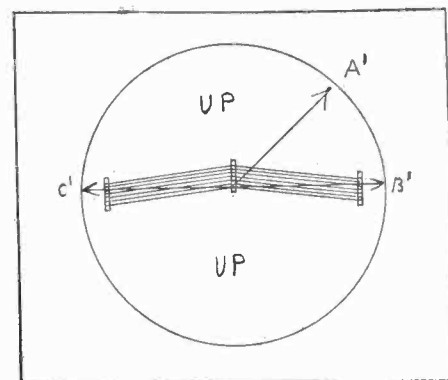

Fig. 2. Straight Wire Reception

two curves, which are approximately circles, are drawn to such a scale that they represent the loudness of a message received in any direction, as the loop is rotated. The way it is drawn is this: Pick up some good station and point the loop straight at it. You can tell its direction because the signal will be strongest. It will be heard fairly loud. Call this loudness 100%, and draw the line OB in the direction along the loop, since it was pointing like that when the station was heard. The line

OB may be any convenient length, which you like, but when drawn it will represent 100% of loudness. Then point the loop in some other direction say about  $45^\circ$  away. This is represented by line A. Now the loudness will be about two-thirds what it was before, so make OA two thirds as long as OB. Point the loop then just at right angles to the sta-

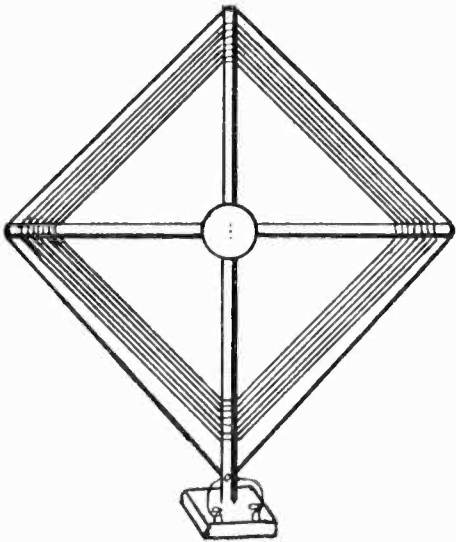

Fig. 3. Wrap One Turn Around Loop. If you have a good loop it will now fade out entirely. Line OR shows this, and it is drawn in dotted since it will have no length at all. By drawing various other lines in the same way and making them proportional to the strength of the signal, we get the circles as shown in Fig. 1.

#### Why Two Circles Are Drawn

You will notice that there are two in this diagram. That is because one side of the loop is just like the other, and so it makes no difference whether the left hand half or the right hand is toward the broadcasting station. As you turn it round through a complete circle it starts loud, then fades out, gets strong and fades out a second time, and so the two circles must be drawn to show this double action.

The action of a straight verticle wire extending up into the air for 25 to 50 feet is shown in Fig. 2. The wire appears in the center as a dot, because you are looking down on it from the top and see only the end. Of course, you can not turn your whole house around, and so you will not be able to plot a curve for it in the various directions. However, this has been tried on ship board where the whole vessel can be steered around in a circle.

In such a test it is found that it receives equally well from all directions. A drawing of its strength would appear as in Fig. 2. Direction A', B' and C' are all made of equal length to tell us that a station would come in equally strong, no matter in which direction it might be situated. If you have an ordinary aerial with a flat top, then the reception will not be quite the same in all directions, but will be slightly stronger at the leading in end of the flat part. The increase is not very great in this direction, however, provided that the level part of the aerial is at least 30 feet high.

#### Two Aerials in One

If you have a loop aerial, and find that it does not give enough strength on some of the distant stations, you can

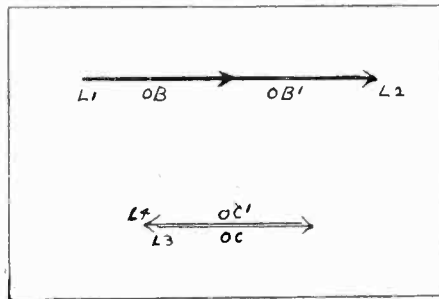

Fig. 4. One Side Adds, One Subtracts

around a box, in which case all turns would be the same diameter or edgewise around a cylinder, like the loop which is used by the Radio Corporation. In any event, to adapt it for use with an outside aerial, it is necessary to wrap a single turn of wire around the outside as shown. It is convenient to bring this down to two binding posts mounted somewhere on the frame. The wire itself may be almost any kind which you have handy, but should be as large as the rest of the aerial, and must be insulated from the other turns.

When nearby stations are going, this extra turn may be disconnected, but when it is desired to reach out just as far as possible, then run the aerial to one binding post (either one) and the ground lead to the other. Of course, a good ground is a great advantage. Your cold water pipe, just where it enters the cellar, is the best place to attach it. You will find that hooking this up as well as the loop, will increase your range several hundred miles. The reason is clear. A big net will catch more fish than a small one.

#### Losing One Direction

It is interesting to notice how the directional effect of the loop is changed

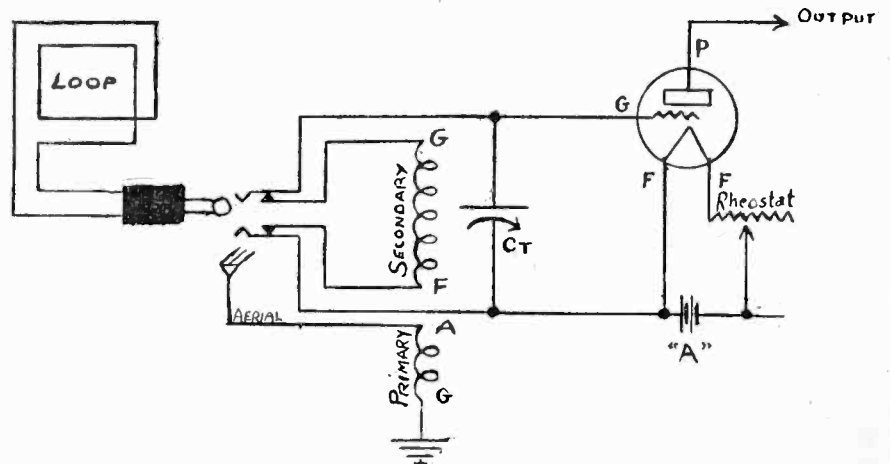

Fig. 5. Automatic Jack Cuts in Loop or Aerial at Will

improve the operation by combining with it a long antenna, either inside or outside your house. Of course, the one outside, since it is considerably larger will give more volume than the inside wire, unless your house is so big that you can get 100 feet without going out doors. The way to connect such a wire is shown in Fig. 3. The loop, as illustrated, is wound in a spiral, with the turns all lying in the same plane. Instead of this it might have been wound

by this extra wire. If this latter is very long and the loop is small, the combination will receive about equally well from all points of the compass, as in Fig. 2. But if it happens to be made exactly the right length, so that the maximum loudness from the loop just equals that from the wire antenna, then a strange effect is noticed. The loop loses one of its two directions, and in the case mentioned at the beginning of this article, the broadcasting station would be picked



up with the loop pointing to the North, but when swung around 180 degrees toward the South, it would be no longer heard. The reason for this action is shown in Fig. 4.

When the loop is pointing toward the station, which we will represent in the direction B, then the loop has a signal strength, OB, and the wire the strength, OB'. We will assume that at that in-

no matter what make yours is. Ordinarily the loop is tuned by a variable condenser Ct. Instead of having the terminals for this condenser connected to binding post or directly to the loop, they are brought to the outside blades of an ordinary four spring jack. The loop is connected to a common telephone plug. It makes no difference which terminal is which. To use the loop, it

into circuit the secondary of the aerial transformer. The primary of this unit is connected to the aerial and ground. The action is then shown by Fig. 7. Primary oscillations flow between aerial and ground, as represented by the radio frequency line labelled P. This is coupled closely to the secondary coil, which causes the waves to vibrate between the grid and filament. The tuning is accomplished by the same variable condenser, Ct, as before. The only operation needed to switch over from aerial to coil and back is merely to push the loop plug in or pull it out. When it is in, the loop is inserted, and you will get all the advantages of being able to tune out a loud local station because of the directional effect of the loop. When it is withdrawn it connects the outside aerial, and you have the large amount of energy which this type collects. This allows you to pick up the distant stations which would be too soft to enjoy any other way.

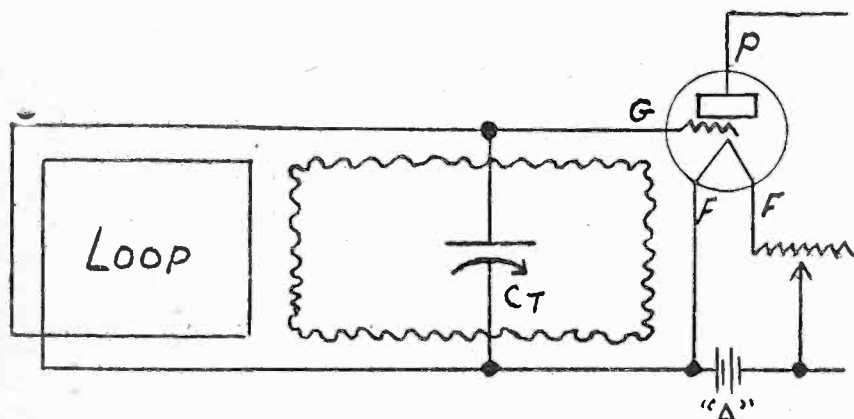

Fig. 6. Oscillation Path When Jack is Inserted

stant the radio frequency oscillation runs up through the aerial, and up through the right hand half of the loop. They will then flow down through the left hand half. Since the directions OB, and OB' are both the same, (up) the two effects will add and we get the line, L1, L2, in Fig. 4. Now suppose we turn the loop around 180 degrees to point in just the opposite direction. The aerial wire does not know the points of the compass, and as Fig. 2 shows, is the same in all directions. OC' will then equal OB' and the direction is still up.

However, the loop has now reversed. To be sure OC still equals OB, but the current at the instant is down. Since the strength of the signals in loop and aerial are the same in magnitude, but opposite in direction, they will just neutralize each other, and cancel as in Fig. 4. OC plus OC' is shown as L3, L4, which has no strength at all. This combination of loop with aerial wire of just the right length, gives a single direction instead of a double to the loop.

**Converting the Set**

Perhaps you may wish to fix your set so that either loop or aerial may be used without the bother of connecting and disconnecting a wire on the outside. Such a scheme is shown in Fig. 5. This illustrates the hook-up of the tuner in any kind of radio set. Only a single tube is shown, which will represent the first one,

is only necessary to insert the plug in the jack, and then the operation will be just as it was before the change was made.

**Winding the Aerial Transformer**

If you wish to wind your aerial transformer, it may be done as shown in Fig. 8. This employs a bakelite tube 3 inches

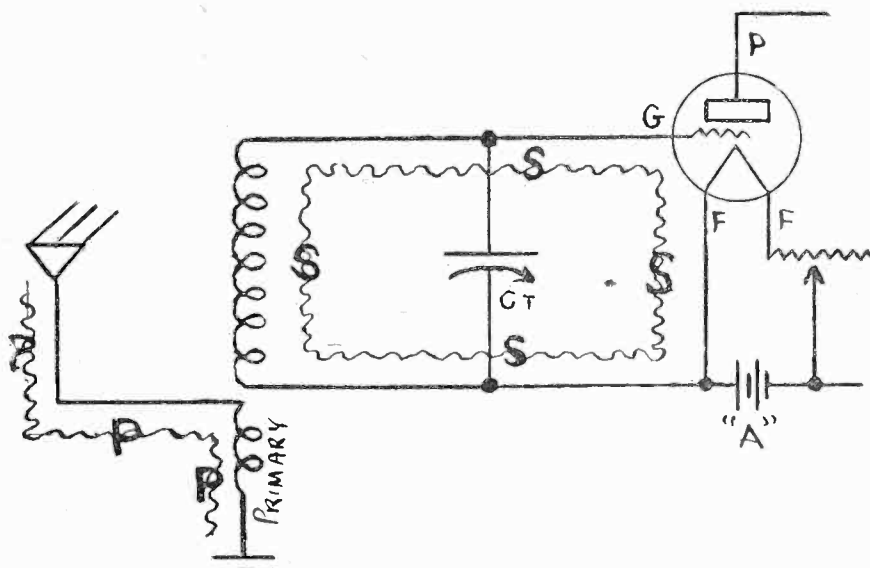

Fig. 7. Path When Outside Aerial is Used

This appears in greater detail in Fig. 6. The oscillation from the loop, tuned by the variable condenser, vibrates back and forth between the grid and the filament as illustrated by a radio frequency line. With such a connection the primary and secondary coils and aerial play no part in the operation at all.

**Connecting the Aerial Transformer**

When the plug is withdrawn, it cuts

outside diameter and 3 inches long. Begin by winding on eight turns of insulated wire. No. 23 is a good size to use, although any other of about the same diameter will be equally good. This should have one covering of either cotton or silk. This is the primary and goes in series with the aerial. The secondary is wound with the same kind of

Continued on Page 28

## Portraits of Popular Performers



Miss Helen Taylor

A newcomer to the ranks of the broadcasters is shown in our photograph. Miss Helen Taylor was heard for the first time in radio recital with Wyoneta Cleveland, the concert pianist, a short time ago. Miss Taylor is a coloratura soprano and has already made a national reputation in concert work.



Dr. Harry Fosdick

Rev. Dr. Harry Fosdick, formerly Associate Pastor of the First Presbyterian Church of New York City and professor of the Union Theological Seminary, is delivering a radio sermon on "Practical Religion" from station WJZ every Sunday afternoon at 3:30 o'clock, throughout the winter season. In his own words, Dr. Fosdick intends "to give the radio audience good straight talks on practical problems of religion; there will be none of the so-called 'religious jazz' in these radio sermons, nor will there be any abstract language. I shall use concrete language and examples in presenting the human side of religion. The talks will be non-sectarian and non-theological."

# Putting Quality into Waves

## *Loud Speakers and Echoes Are Both Important*

By Dr. ALFRED N. GOLDSMITH, B. S., Ph. D., Fellow, I. R. E., Director of Research, Radio Corporation of America.

**T**O compress an entire orchestra into a tiny round disk—this is the bold demand of the modern radio engineer. He insists that the loud speaker shall reproduce perfectly for the radio listener the concert which is being given at some broadcasting studio. The problem is really a comparatively recent one.

While telephone receivers have been known for fifty years, they were generally adapted only to reproduce the voice feebly and with only fair accuracy. You had to press them to your ear to understand at all well, and they failed to reproduce music with any reasonable satisfaction. If it were attempted to make loud speakers of them, by attaching a horn, they rattled and distorted the music badly. New electric and acoustic laws had to be developed to meet the requirements of an effective loud speaker. Only after considerable research and experiment has it become possible to produce such devices which will accurately follow their vocal masters at the broadcast studio.

### Speaker is Hard to Build

A little thought will show why building a good loud speaker is so difficult. It must reproduce faithfully all sounds, starting from frequencies as low as fifty vibrations or cycles per second (corresponding to the deepest tones of the organ and piano). It must also handle up to as high as eight or ten thousand cycles, the speed of the highest overtones of the violin or piccolo and certain of the tones of the spoken consonants "s" and "f." It must be able to produce soft pure notes, and also extremely loud ones, so that the expression and meaning of musical compositions or oratorical efforts will not be lost. It must accurately reproduce, in the right proportion, the voice and its piano accompaniment, or the various instruments which blend together in an orchestra. And, when final-

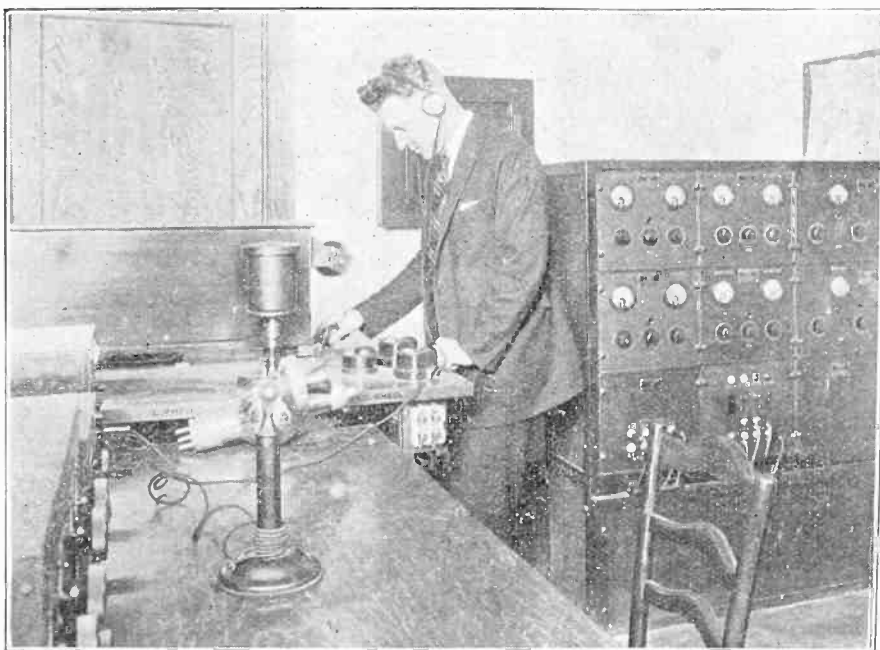

Fig. 1. "Listening" to Music with the Eyes

ly made, it must be good looking or even ornamental, since its place is generally in the home.

Great care is taken at high-grade broadcasting stations to insure high quality in the concerts sent out. In fact, a great deal of the distortion which is often blamed by some on the station is really due to their poor speakers. Many have had the experience of listening to an exquisitely rendered concert from a certain station on one receiving set, only to be amazed at its poor quality on a nearby set. It is for this reason that the listener should not condemn the quality of a concert unless he knows that his receiving set is correctly designed and used, and that his loud speaker is a good one.

### Watch Wavering Waves

The method of supervising the quality of transmission by both ear and eye at stations WJY and WJZ, of the Radio

Corporation of America, Aeolian Hall, New York is shown in Fig. 1. The supervising engineer listens to the quality of the music on a special receiving set, and at the same time watches a wavering line of light on the oscillograph mirror. From this he can tell the strength, and to a great extent, the quality of the outgoing concert. The radio fan would be amazed to see how extremely complex the sound waves are, as shown on the oscillograph mirror. They look more complicated than a line of ocean waves in a bad storm. It is really one of the great achievements of science that such complicated sounds should be reproduced at all, especially by so simple a unit as a circular disk or diaphragm.

### The Insides of a Speaker

Loud speakers in general include a strong magnet, which is usually a permanent steel magnet or, in a few cases like the power Magnavox and the



Thorphone, it is electrically-excited, which requires battery current for its operation. There are also one or two coils of wire, generally wound over the permanent magnet poles, through which flows the electric current which carries the music in the form of regular or irregular fluctuations in this current. In some loud speakers, an iron diaphragm is set into vibration by the variation of

short horns emphasize the higher pitched notes. However, so much depends on the angle of the horn opening and on the way it is attached, together with the characteristics of the telephone receiver portion of the speaker, that no general statements can be given here as guides to what constitutes a suitable horn.

In the development of the new Radiola

low pitched notes, but does respond to high tones. Speech will be fairly intelligible on such speakers, but the piano will sound thin and much like a harp or guitar. Base voices will be weak or else sound like thin baritones. The effect in rendering orchestral selections will be feeble and squeaky, and without "body" and roundness. The accompaniment of the cellos and violas, and other deep-voiced instruments will be lost. The general effect will be that of a cheap and poorly designed toy phonograph with a small horn.

#### Murdering the Music

3. The loud speaker may reproduce only notes in the middle register, dropping out high and low pitched notes. This is unfortunately a fairly common fault. While speech is moderately intelligible on some examples of this class of instruments, music is very unmercifully treated, and the faults found are a combination of those mentioned in 1 and 2 above.

4. Loud speakers should not rattle on the loudest notes which are produced; but the user should be cautious in drawing conclusions, since he may be overloading his vacuum tubes by excessively loud signals, combined with low plate voltage and incorrect grid bias. Unless the listener is sure the radiotrons are not themselves being "saturated" or overloaded, he should not blame the loud speaker for rattling noises. The best way of checking up on this point is by trying a known reliable loud speaker on the set in place of the suspected one.

#### Sometimes They Are Dumb

5. Loud speakers occasionally are insensitive; that is, they fail to respond to weak signals at all, and do not work well even on reasonably loud music. The only test is by comparison with one known to be O K.

6. Some loud speakers, while otherwise fairly satisfactory, reproduce combinations of instruments (voice and piano, or violin and piano) with less satisfaction than solo efforts. This fault requires for proof of its existence a careful listening test on a suitable selection from a broadcasting station of proven high quality.

#### Your Home Not a Laboratory

It is not implied that the above rough listening tests are an effective substitute for a precision laboratory test of a loud

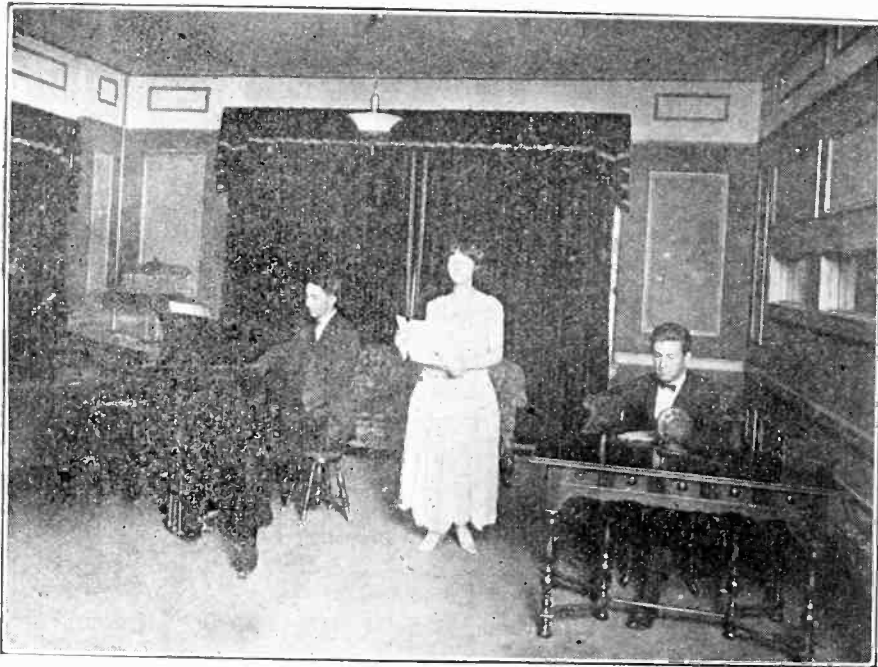

Fig. 2. How Echo is Controlled at Station WRC

magnetism caused by the incoming electrical current carrying the music.

In others, diaphragms of mica or other material are made to oscillate by mechanical systems attached to them, which, in turn, are controlled by varying magnetic pulls on an iron movable part of the system. The exact arrangement of the insides of the loud speaker is therefore not standardized, but what is required from the instrument is well-known to the experts. Elaborate electric and sound laboratories have been established by the leading radio companies for the continued development and improvement of the device.

#### Making the Horn Itself

Practically all loud speakers are provided with a horn of wood, fiber, paper mache, plaster of Paris, or some other material which is believed to be suitable. A great deal of the quality and sensitiveness of the loud speaker depends on the materials, shape, and mode of attachment of the horn. As a general rule

loud speakers, which have been designed after many experiments in the laboratory, thousands of accurate measurements have been made to avoid the common faults of most loud speakers. Such tests represent a most interesting development in the field of sound.

The principal faults of some loud speakers, and the general listening tests for them are:

#### What is Wrong With Your Horn

1. The loud speaker fails to reproduce high pitched notes, altho it gets the low tones all right. Such instruments will sound well on piano pieces in the lower register, and on base voices. Tenors and sopranos will be thin and weak, and the violin will lack its true tone, being "flattened out" into flute quality. Speech, and particularly feminine speech, will not be fully understood. Orchestral selections will sound noisy and will have a drumming quality.

2. The loud speaker fails to reproduce

speaker under proper conditions. Wrong conclusions may sometimes be drawn from a single unsuitable listening test with the loud speaker fed from an unreliable broadcasting station or from an unsuitable receiving set, yet these suggestions do give a general idea of the defects of some loud speakers.

It may be said that radio broadcast reception stands or falls in large part on the merits or defects of the loud speaker, since it is this device which finally produces the desired entertainment. It is therefore, too bad that so many inferior articles of this type have been placed on the market by manufacturers who were actually ignorant of the requirements of the problem. The influence of such speakers on the reputation of radio reception has been bad. Fortunately tests and exact design methods are now available, and first class loud speakers can be obtained. Continued improvement in these devices may also be expected until it will become nearly impossible to distinguish between loud speaker output and the original musical instrument playing in the studio. A further means of bringing this about is found in the treatment of echos in the studio.

#### Echo Must be Controlled

When echo answers a call of welcome in a mountain ravine, the effect is delightful. But when echo blurs the sharpness and clarity of a broadcast concert, a remedy must be found. Probably few persons realize the extent to which echo or reverberation hurts broadcast music. Because of this, various measures are necessary to overcome such defects.

If you stand in a large empty hall, (particularly one with covered wooden, plaster, or brick walls, such as an armory) and whistle sharply, the sound is prolonged into a continuously fading note which may last five or ten seconds before it sinks into silence. If several notes forming a tune are whistled, the echo blurs the melody badly; and if an orchestra plays in such a hall, the effect will be confused and disappointing. Acoustic experts, who have specialized in the field of sound have coined a term, "reverberation time," which measures the time the echo lasts, or to be exact, the time it takes the echo to drop to a loudness only one-millionth ( $1/1,000,000$ ) of the original sound intensity. The fraction one-millionth has been chosen because it is found that the normal ear

cannot hear the echo of even a loud sound when it has diminished to such a small fraction of the sound which produced it.

#### Must Avoid Smudging Sounds

The reverberation time of a concert hall is therefore of very great importance. If this is too long, blurring echoes will ruin the orchestral music, particularly in the louder passages. Speech will not be understood, and the entire reproduction will be "smudged." If, on the other hand, the reverberation time

artistic judgment where little difference of opinion exists.

In broadcasting concerts, the problem of avoiding excessive echo is even worse. There are two echoes to be considered. If the artist performs in the studio, the reverberation time of the studio must be taken into account, since it is the effect of his performance in the studio which is picked up by the microphone. The music is then reproduced by a loud speaker in your home. But your room also has echoes and its own reverbera-



Fig. 3. A Receiver Like This Checks Quality of Broadcasting

is too short, while the music will be clearly defined and sharp, it will have a cold unsympathetic quality and the hall will sound "dead" and without "resonance" or "response." Musicians find too short a reverberation time nearly as unpleasant as one that is too long. Hundreds of trials have shown that musicians prefer halls having a reverberation time of one and two-tenths seconds. There is a rather astonishing agreement on this value among skilled musicians, and it is one of the few matters of

tion time, and the blurring effect of the room in which the reproduction takes place is added to that of the studio. So if the studio has a time of two seconds and the living room in the home one second, the echo effect on the music produced will correspond to that in a hall having a reverberation time of three seconds. This will be quite excessive, and the listener will be disappointed in the effect produced even though every other stage of the broadcast transmis-

Continued on Page 12



### INSURANCE BY AIR

The Travelers Insurance Company, of Hartford, Conn., will soon go on the air with one of the finest and most powerful broadcasting stations in the United States. The new station, which will be located at Hartford, is expected to be in operation some time early in December, according to Walter G. Cowles, Vice-President. He said the company was "sacrificing speed for efficiency" in making the installation.

Following Stations WDAR, Philadelphia, and WGBS, New York, in broadcasting with storage battery power instead of motor generators, the new Hartford Station also will be so equipped. The results obtained by these two stations show that by using storage batteries, and so eliminating the commutator hum of a motor-generator from the carrier wave, the strength and clearness of the signals are increased somewhat. This hum is the result of disturbances set up by the high-voltage direct-current generator every time one of the commutator segments makes or breaks connection with the brush which carries the current to or from it.

#### Nearly 1000 Cells Used

The broadcasting power equipment of the new Hartford Station will consist of a 1760-volt plate circuit battery made up of 880 cells of "B" battery, designed especially for radio broadcasting and receiving services. An 18-volt "A" battery consisting of 9 cells, will light the filaments.

These batteries of Philco manufacture are the glass-case type mounted in supporting trays of 20-volt units. The glass containers are tightly sealed with a new form of cover having a spray-proof filler-vent which condenses and feeds back into the cell any spray that tends to pass during charging. They are also equipped with built-in charge indicators which tell at a glance when the batteries need recharging.

#### 300 Feet Down to Ground

All transmitting and power equipment of the new station is located in a special building erected on the roof of the company's eleven-story office building in Hartford. On the roof are also two towers each 150 feet high, the tops of which are 300 feet above street level.

The entire building, according to Vice-

President Cowles, is electrically shielded to prevent the least possible outside interference, and no alternating current will be used inside the building even for lighting purposes. The studios, control room and reception rooms are on the sixth floor of the building, and are of absolutely sound-proof construction.

"Our present plan," said Mr. Cowles, "contemplates five branch speech wires, one to each of the two studios, receptacles being placed across the circuit at convenient points in the baseboard for connecting up the cable to the microphone. A third circuit is within the control room, and is used wholly for announcing. A fourth goes to an assembly hall on the second floor, where gatherings are frequently held, both for social and business purposes, and broadcasting from that point may occasionally be undertaken.

#### Ready for Remote Control

"The fifth branch line goes direct from the transmitting room to a telephone junction box by means of which external circuits for distant control are obtained. This is for such use as we may make of it as our broadcasting plans develop. It will permit us to operate by means of remote control from any point within convenient distance from our studios.

"At the present time I am unable to make any announcement, even of a general character, respecting the nature of our broadcasting offerings. I can only say that we shall make every effort to make our station distinctly worth-while, and put out such material as will interest the public."

### PUTTING QUALITY.

Continued from Page 11.

sion and reception has been correctly carried out.

#### Fooling the Artists

It therefore becomes necessary to reduce the studio echo to a low value so that the combined studio and home echoes will not be excessive. The method of acoustic correction of a studio is illustrated in Fig. 2. This shows the studio of station WRC of the Radio Corporation of America at Washington, D. C. The walls and ceiling of the studio are first covered with a thick layer of a special variety of felt, chosen because of the very slight reflection of sound from it and the consequent deadening

effect on echoes. Over the felt is left an air space, and then heavy non-inflammable muslin is fastened in place with suitable moulding to give a panelled effect. The whole is thinly painted in appropriate colors. All doors and windows are similarly protected by heavy velvet or plush hangings, and the floor is covered by a thick soft carpet. Heavily upholstered furniture is used. Under such conditions, the echo in the studio is greatly reduced and the reverberation time is kept quite low. The artists frequently object to studio effect as "dead," not realizing that the reverberation in the home reproduction will add the necessary softness of quality to their performances and that, if the effect satisfied them in the studio, it would certainly not satisfy them in the home.

Some experimental work has been done in the exact regulation of the studio reverberation time by roller curtains properly placed in the studio, which curtains can be drawn back thus exposing hard reflecting surfaces and increasing the reverberation time. While the general requirements for studio design are now well understood and have been met, the whole subject is still under investigation and improvements may be expected from time to time.

#### A Big Audience Helps

The nature of the installation in the home is far from indifferent as regards the effect produced. As a general rule, echo is worst in large rooms, in those with hard surfaced walls, in rooms having wooden furniture with little upholstery, and with few people in the room. Conversely, echo can be reduced in the home by curtains or hangings, heavily upholstered furniture, by using a small room, and by having an audience of several people sitting not far from the loud speaker. It is because of these considerations that identical receiving sets and loud speakers, properly used on the same reliable transmitting station will give different effects in different homes. This fact has been very generally ignored in the past, but it is of importance to persons of musical taste who wish to get the utmost out of broadcast reception.

Another effect which has been noticed by careful listeners is that the positions of the loud speaker and of the listener in the room have a considerable influence

Continued on Page 18

# Tracing Signals Through Regenoflex

## A Reflex Circuit Which Uses Push and Pull Audio

By OLIVER D. ARNOLD

WITH all the circuits on the market which are one or another kind of "dyne," it is pleasant to turn to a circuit which has the name of "Regenoflex." This is proving one of the popular radios this season. There is some question how the set operates.

In general, it may be described as a four-tube set, which uses one tube for radio and reflex audio amplification, a second tube as a detector, and a third and fourth combined as a single step of push and pull audio amplification. Thus the hook-up combines the distance of radio amplification, the loudness of two steps of audio, and the smoothness and lack of distortion of push and pull, all with four tubes.

### Road Map of the Waves

Refer to Fig. 1 to see how the music reaches the loud speaker. The waves strike the aerial and run down through the tuner to the ground. This tuner consists of the ordinary combination of inductance (coil) and capacity (condenser) and by adjusting the values, the proper wave length may be picked up, just as in any other set. From the tuner the radio frequency is conducted to the first tube, as seen from the front of the instrument. This is a radio frequency amplifier. Here the amplitude, or loudness, of the oscillations is multiplied about five times, and from there directed through the primary of the radio transformer.

The secondary of this last unit is connected to the grid of the detector tube, No. 2. Here the frequency is reduced to a low speed of vibration of a few hundred, or a few thousand, depending on the note, which the musicians are sounding at the moment.

### Reducing 1,000,000 to 100

Thus the wave passing from Tube 1 looks as shown in Fig. 2. Here we see a large number of high speed waves com-

ing in at the rate of about one million per second. The detector, tube 2, reduces this high frequency down to the audio speed of a few hundred, as just mentioned. The wave, leaving the detector, is illustrated in Fig. 3. Notice that the shape of this last curve is just

to work the phones on distant stations, and will operate a loud speaker on local signals. In order to make the volume a lot louder yet, so that distance can be handled by a horn, the audio waves are fed to a push pull transformer connected to the plate of tube No. 1. This trans-

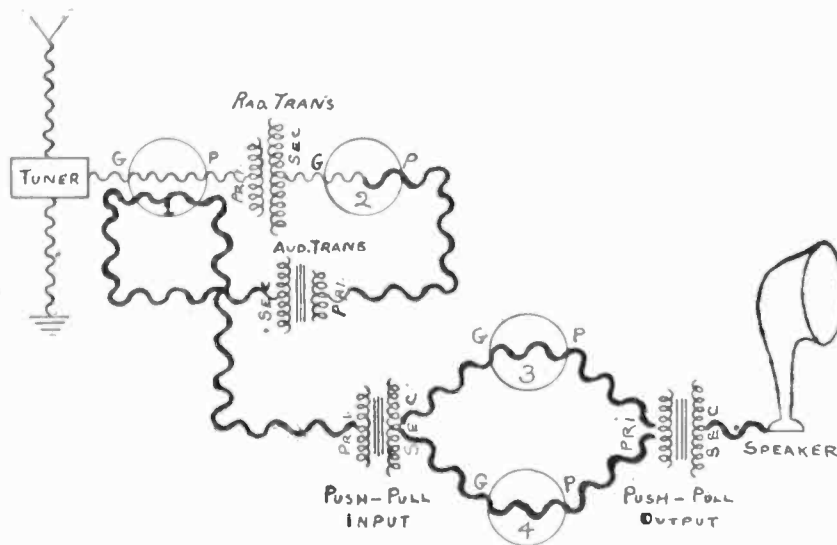

Fig. 1. Wave Paths. Light Line, Radio; Heavy, Audio Frequency

the same as the outside curve of Fig. 2. That is what the detector accomplishes in any ordinary set.

In our diagram Fig. 1, we use a thin wavy line to indicate that the vibrations are at high speed, or audio frequency. Beyond the detector they are at low frequency, which is indicated by the heavier wavy line. The output from the plate of the detector is then fed to the primary of the audio transformer, and the secondary of this unit impresses the signals on the grid of the first tube. They are not confused at all because of the very great difference in the speed of vibration compared with the radio waves which are entering at the same time.

### Working the Push Pull

The output from the first tube at audio frequency has now become loud enough

former differs from the output of the detector and the input of the first step in this way. The latter transformer has only four terminals, but the push pull transformer has five. The primary is connected with one end to the plate and the other to the "B" battery as usual. The secondary has a middle tap, which is grounded to the filament of tubes 3 and 4. The two ends of this winding, however, are both alive, and one goes to the grid of tube 3, and the other to the grid of tube 4. This puts the audio frequency on both tubes at the same time. The output from the plate of each of these bulbs is recombined in the output push pull transformer which also has five terminals. The secondary from this transformer is connected to the loud speaker.

Getting back to the radio frequency amplifier No. 1, care must be taken not to allow any self-oscillations, as these would be radiated by the aerial and cause annoyance to the neighbors. Furthermore, oscillation at this point would make the signals sound mushy. The detector, on the other hand, should be made

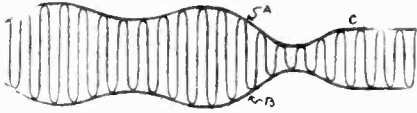

Fig. 2. Wave Going to Tube 2

to oscillate to get the most out of the distant stations. This is the place for regeneration. It will not disturb the surrounding country, because tube No. 1 will feed vibrations only from the grid to the plate, that is from left to right, and like the turnstile in an exit passage no traffic can go in the reversed direction. The amount of regeneration or feedback is controlled by the tickler in the ordinary manner.

#### Adjusting the Set

In getting the correct regulation of the outfit, it is just as well to begin at the loud speaker, since this is easy to correct if it is set wrong. There is a control for the length of air gap between the diaphragm and the magnet poles. This gap should be changed until the music comes in loud and clear. There is no reason for further change in it, unless on a very loud local station, the diaphragm should happen to hit the pole pieces in its very great vibration. In such a case it would be necessary to increase the distance between them slightly.

Fortunately, in this set the tubes themselves are not very critical in their action. This is quite different from superheterodynes where the utmost care must be used in selecting special tubes for oscillator and detector. The WD-11 bulbs, which come with this outfit, may be interchanged from one socket to another and results compared. However, if any material difference is noticed, it shows that some one tube is defective. In such a case it should be exchanged for a good tube. Once the position of these four units has been found to be best, it is well to number each tube with a lead pencil on the bottom of the base, so that they can be returned to their ori-

ginal position any time they are withdrawn.

#### Retune Each Time

In making these changes, and in fact any changes in the installation at all, it is necessary to retune with the station selector every time a shift is made. If this is not done the slight variations in the values of different parts may throw a station slightly out of tune, with the result that the falling off in volume is blamed on the change, when it really is the fault of the operator. Also, in shifting tubes, be careful to open the "A" battery switch each time so that excess voltage will not be applied to the filaments during the time that some of the tubes are out of their sockets.

If tube 1 or 2 is removed, while the set is running, it will completely kill the operation. You may be surprised to find, however, that when either 3 or 4 (but not both) is taken out of its socket, the program will continue to come in just about as loud. The reason for this may be seen by again looking at Fig. 1. Notice that the output from the push pull input transformer divides and goes to both 3 and 4. Since the energy is divided into two parts, each will naturally get only one half. When one of the bulbs is removed then the energy is no longer divided, but all runs to a single tube. In one case, then, we have two half portions added up, and in the other one whole portion. Naturally the latter case shows just about as loud as the former.

#### Why Use Two Tubes

Perhaps you may ask why two tubes are used, since one will give nearly as loud results. The explanation may be found in the fact that with two, each tube takes only half the energy, and for that reason is much more efficient. The set is so powerful that when all the energy is fed to a single tube it is apt to be overloaded, with the result that the music is distorted and the loudness suffers slightly.

Another reason for using the push pull is because each tube has irregularities of its own, and by adding the two tubes together the results are smoothed out somewhat. This action is noted a great deal more on local stations than on distant ones. This follows because the far away music is soft enough so that it does not nearly approach the capacity of a single unit.

#### Aerial and Ground

This set is not designed to work with a loop, even though it does have one step of radio frequency. For such operation at least two steps are needed. An aerial of something like 150 feet is recommended for best results. Of course,



Fig. 3. Waves from Tube 2

a good ground is an advantage for almost any set. It is well to fasten the ground lead direct to the cold water pipe right near the water meter.

Dry batteries are supplied for use with this set, as the tubes require a pressure of 1 1/10 volts. The new dry cell has a potential of 1 1/2 (1 5/10) volts, so the difference, 4/10 volts, must be absorbed in the rheostat. As the batteries grow old they weaken, and so the rheostat must be turned farther and farther toward the full on position. If care is taken in not advancing the rheostat any more than necessary, it will be found that six dry cells last two months for average use. The "B" batteries will hold up longer than this provided a good grade is employed.

#### 25 YEARS FOR ENCORE

The last music a Schenectady woman heard before deafness came 25 years ago, was Gounod's "Ave Maria." A radio set was recently installed in her home and the first sound she heard, the first music after 25 years of silence, was a violin selection, "Ave Maria," played by Edward Rice of the WGY Orchestra.

#### TALK ABOUT KEEPING TIME

The Remington Typewriter Band, playing at WGY, Schenectady, accompanied a church choir singing at Providence, R. I., broadcasting station, according to E. L. Fuller of the latter city. "That band," writes Mr. Fuller, "was playing a medley including 'Massa's in the Cold, Cold Ground,' and the choir was singing the same song at exactly the same time. I made a split on dial settings, and could get both. The band kept perfect time for the singing until the last few bars, when the band won out."

# Do We Want Resistance or Not?

*A Benefit in Some Places,  
a Drawback in Others*

By ERNEST W. SAWYER, Chief Engineer of the Electrad, Inc.

WE all hear so much about winding of coils in such a way as to cut the resistance down as much as possible for sharp tuning, that we are apt to get the idea that it is always a bad thing to have resistance in a radio circuit. A moment's thought will show us that in some places it is needed. For instance, there is the rheostat. With-

ance is needed to operate correctly is in the grid circuit between the tuning coil and the grid of the detector tube. This is shown in Fig. 1. Here is illustrated a hook-up, which is made non-regenerative, so as to be as simple as possible to describe. Of course, the operation of the leak will be just the same in a regenerative, neutrodyne, or other more complicated set. The grid condenser, which always accompanies the leak, serves to insulate the grid terminal from all the rest of the surface as far as direct current is concerned. The high frequency A. C. passes through the condenser without experiencing any appreciable obstacle.

The leak might be considered as a dam to hold back and govern the flow of electrons to the grid. It was this use of an Electrad "variohm,"  $\frac{1}{4}$  to 30 megohms, by Mr. F. A. Hodge of Brooklyn in his \$15 Haynes-Griffen set that permitted him to get London in the famous Wanamaker test of April, 1924. This use is well adapted to regenerative and ultra Audio circuits and can be used very successfully in the superheterodyne such as that used by Paul Godley in the famous receiver which he used in the first Trans-Atlantic tests held in England. The explanation of the action of the leak here is as follows:

When waves enter the tuner from the aerial, the grid is affected with an alternation of positive and negative waves. The flow of electrons from the filament is increased when the grid is positive, but is hindered or prevented, when the grid is negative. This is because of the well known action of electricity that opposites attract and like repel each other. Since the little particles of electricity or electrons, which are shot off from the hot filament are all negative, it follows that a positive charge attracts and a negative charge repels them.

## What the Grid Does

If we want to get a large current at any instant, then of course, we must speed up the electrons and get a lot of them because that is what the current is. How shall we do it? The natural way is to give them something they like, in other words, a positive charge. The grid is located close by the filament in

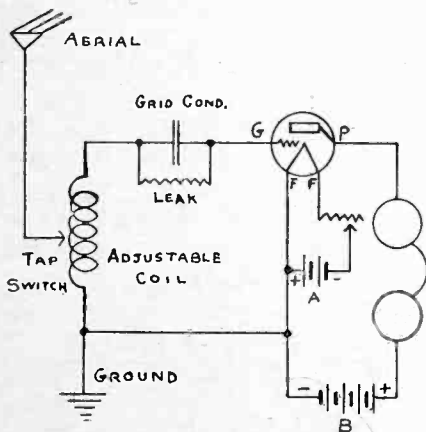

Fig. 1. Note Position of Leak

out it the voltage on the tubes would be so high that it would shorten their life to less than half.

The exact theories of the action of resistance in radio circuit as mentioned below, are not completely understood by most fans. Here is a fertile field for research and experimentation for those interested in getting the best results. Luckily, the devices available are designed so as to permit even those with little radio knowledge to fool around and obtain excellent results.

It is enough to say that anyone can get good results by trying one or more of the following suggestions. Try them and be convinced. Study the reasons for your results and you have a man-sized problem on your hands.

### Variable Grid Leak

One of the first places where a resist-

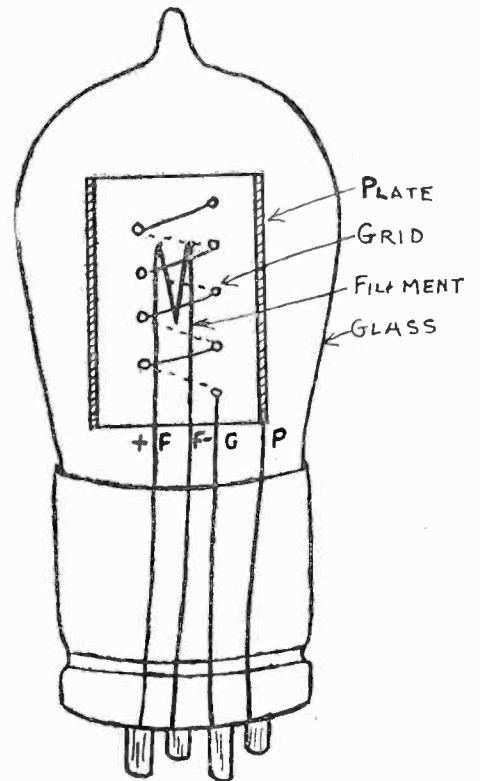

Fig. 2. Assembled Tube Elements

the vacuum tube, and putting positive electricity on the grid is like showing a dog a big piece of meat. The dog comes rushing out from his kennel, because of the attraction, and in the same way the negative electrons come rushing out from the filament under the influence of the plus charges on the grid.

You may wonder why the electrons don't go to the grid if that is what they are after. As a matter of fact they do,

and that is why the grid leak is necessary. But only a small proportion of the total electrons which leave the filament are able to strike the grid. This is because its wires are so small and fine, and are spaced

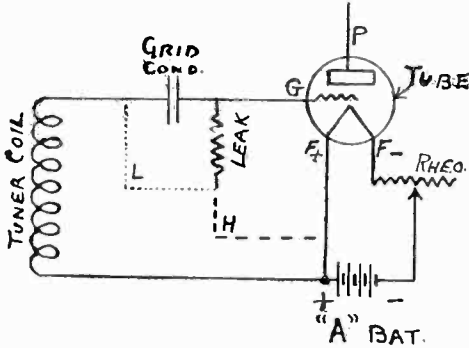

Fig. 3. Two Ways Connecting Leak

so far apart. Most of the electrons, which are traveling at high speed, aim for the grid, but miss it, and so rush across to the plate where they become the plate current.

**Just Like a Bargain Sale**

Their action is just like a bargain sale in a popular department store. The

They are all after the stockings (grid). But how many are able to get them. There are not nearly enough to go around, but once they have been attracted, they keep on going and buy something else in the store (plate). Of course, a small proportion of those that come, actually get what they want (positive charge). You can readily see that if there were enough stockings to give every one all she wanted, then she might not buy very much of the other merchandise. And in the same way if the grid in the tube were built of large wire occupying most of the space, the electrons would get their fill of the plus charges on the grid, and so not many would get across to the plate where they are used. That is why the grid wires are small and widely separated. This is shown in Fig. 2.

The little ups and downs of the radio waves, however, come in thick and fast, and the grid endeavors to take care of them. When a negative half wave strikes the grid you might suppose that it would attract positive electrons, but "there ain't no such animal." All electrons

these fortunate ones—where will they go? It is certain that they can not be discharged to the left as shown in Fig. 1 through the grid condenser, because the latter will not conduct current in a single direction. That is, it will allow an oscillation to pass, but not a steady stream going either way. If there is no grid leak, these little mites of negative electricity will pile up on the grid until it becomes so strongly negative that it chokes off with its repulsion all the new born electrons which would otherwise come from the filament.

**Grid Leak to the Rescue**

This is where the grid leak shines. It allows the electrons, which have been lucky enough to find the grid, to be conducted harmlessly back to the filament. It is now easy to see what the effect of more or less resistance at this point will do. If the resistance is too high, then the negative charge can not leak off very fast, and as a result it will pile up to a considerable value. This will have the effect of repelling in a large measure the electrons which would otherwise start crossing to the grid and

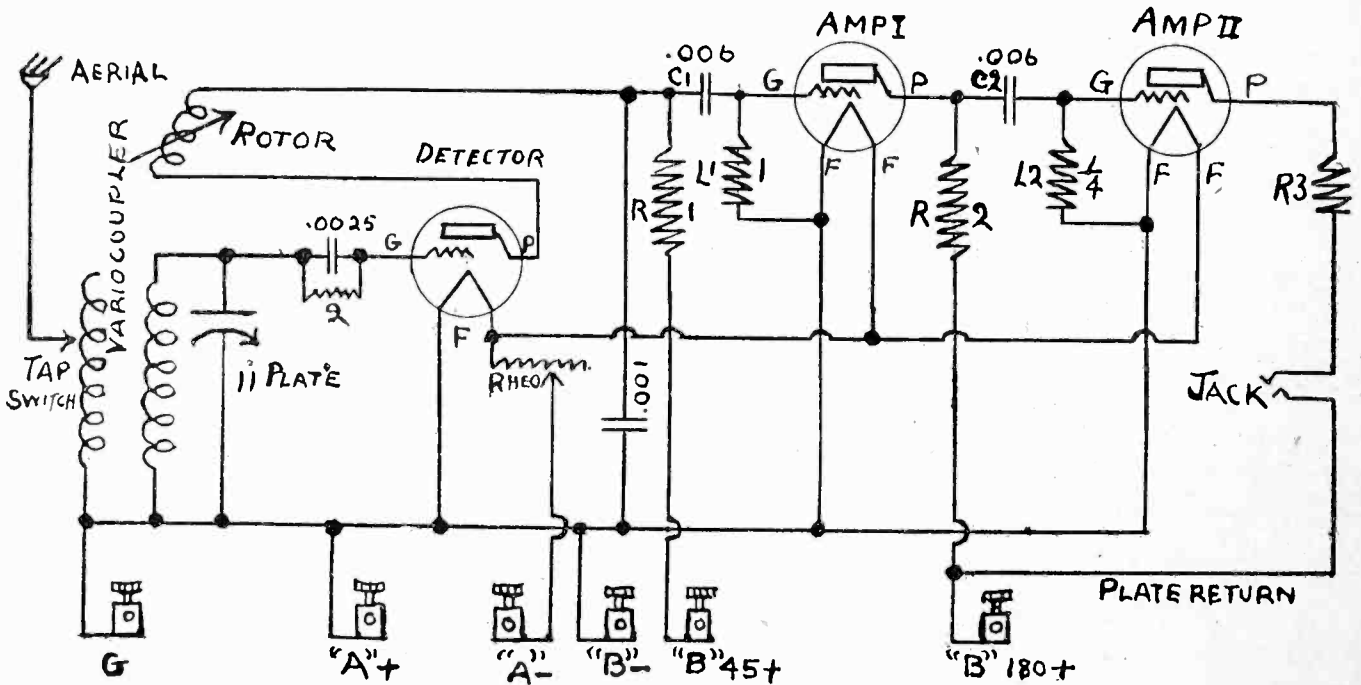

Fig. 4. Grid Leak Must Run to Filament + to Avoid High Voltage from "B" Battery

managers want to attract the women, so that they will buy his goods, so he advertises "Pure Silk Stockings" at \$1.00 per pair. All the girls are naturally attracted and they come in large numbers to the store.

have negative charges, and so no positive charge gets across to the grid. On the positive half wave the negative electrons are attracted as just described. You will remember that some of them actually reach the grid. What about

eventually reaching the plate. Naturally, the signals would not come through so loud in such a case.

If, on the other hand, the grid leak is too low, the action becomes irregular, and the tube usually will break into os-



cillation with a pop. This prevents smooth control and makes the set hard to regulate. Both these conditions (too much, or too little resistance) have their biggest effect when the signals are weak. The local program is usually so loud that the music will be satisfactory whether the leak is large or small.

**Two Hook-ups for Leak**

The most common use of a variable leak is in the grid circuit of the vacuum tube. There are two ways of connecting it. One end of the leak always goes to the grid. The other connection is shown in Fig. 3. One possibility is to run the other end of the leak to the other

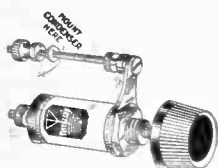

Fig. 5. An Adjustable Grid Leak

side of the grid condenser. This is shown by the light dotted line L. The other way is to connect it direct to the positive of the "A" battery. Heavy dotted line, H, gives this method of connection.

Since the resistance of the leak is in the neighborhood of a million ohms, practically no alternating current (A. C.) goes through it. Instead the radio frequency uses the grid condenser, which offers practically no obstruction to the flow of such rapid oscillating electricity. Direct current can not pass through a condenser of any size, large or small, and so it is forced to use the path through the leak in spite of its high resistance. With this in mind notice that line, L, and line, H, both go to the plus of the "A" battery, the only difference being that the current through L has to go through the tuner coil in addition to the leak. Since this coil has a resistance of only a few ohms, it is lost in comparison with the millions of ohms in the leak. For that reason it makes no difference from the electrical point of view, which of these two connections is used.

**This Way is the Easier**

As a matter of convenience, it is found that the best place to connect the leak is that shown in L. This is because the grid condenser must be used in any case, and it is easier to make use of these terminals rather than run a wire to the

plus of the "A" battery. That is why connection L will be found as standard in most sets.

There are a few hookups, particularly those which use resistance coupled amplifiers, which must employ connection H. An illustration of this is shown in Fig. 4, which is a reprint from the diagram of connections illustrated in the article on resistance connected amplifiers which appeared in our November 1st issue. Notice that leak L2, for instance, connecting the grid of amplifier II, is hooked up to the "A" plus terminal. The left hand side of the condenser, C2, runs directly to the "B" 180 plus. If the leak had been connected across condenser, C2, in the manner described above, then this very high voltage would have been impressed on the grid and the tube would not have operated. By using the other scheme of connection as shown, the electrons from the grid can leak to the filament without having any "B" battery pressure applied to the grid.

A convenient type of variable grid leak to use is the variohm. This is pictured in Fig. 5. It has the advantage that a standard size grid condenser, like a Micadon can be screwed right to the terminals, as they fit the spacing of the holes in the condenser. This makes a very neat way of mounting. If some other style of condenser is used, of course this particular feature can be disregarded.

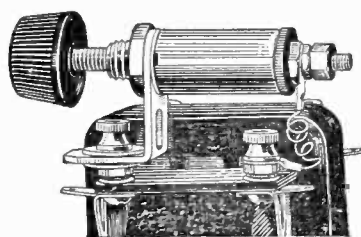

Fig. 6. To Prevent Distortion

**Adjusting the Neutrodyne**

Possibilities of using a variable resistance of 1/4 to 30 megohms in neutrodyne circuits so as to combine capacity and resistance neutralization are worth looking into. The merit of this is still subject to considerable discussion as are also the comparison with ordinary capacity neutralization.

There are other places where variable resistances may be successfully used, such as in series with the loop, or from the antenna to ground, etc. When used

from antenna to ground, as pointed out by Zeh Bouck, it may be considered as a static discharger, relieving the antenna of the tension which would otherwise cause disturbing clicks.

**As a Static Reducer**

In such a case it must be connected so as to short circuit the series condenser, which is in the aerial or ground lead. Owing to its high resistance it does not by-pass an appreciable amount of radio waves. But it does let through the charge of direct current which would otherwise accumulate in the condenser. If your hook-up uses no series condenser

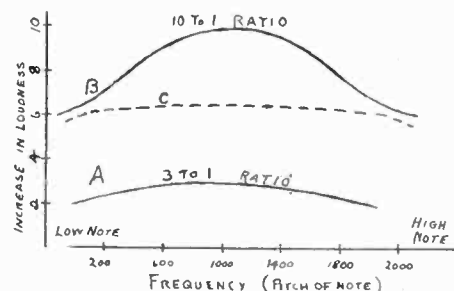

Fig. 7. Loudness Curves

in either aerial or ground, then no good will be accomplished by a resistance in this position.

Another place to try a variohm is from the grid to the detector tube to the plate of the second or third tube. By such a connection some forms of distortion may be reduced. If that is the case in your set you may expect that the music will come through a little clearer. Still another place where a high resistance may be used, is a by-pass across the primary of an audio transformer.

**Making Music Clearer**

As a distortion remover, you will sometimes find it is an advantage to try a variable resistance from 10,000 to 120,000 ohms, placed across the secondary of your audio transformer. The Audiohm has been especially adapted for this purpose. See Fig. 6.

This is an important use and I explain the phenomena this way. Audio transformers should give an equal voltage amplification over the entire tone range of 200 cycles to 2000. Practically, this is impossible at a reasonable cost. Some audio transformers on the market selling even at \$6 or \$7, give rather poor results if used below 300 cycles. If the

Continued on Page 22

# American Radio Relay League

## MIX GIVES THEORY FOR DIRECTIONAL EFFECT

A solution of the mystery surrounding the reception of radio signals from the West, at Donald B. MacMillan's winter quarters at North Greenland has been offered by Donald Mix, American Radio Relay League operator for the expedition. It will be recalled that during the winter months at Refuge Harbor, signals from amateur stations in the western part of the United States and Canada came in clearly, while those located east of the Mississippi were scarcely heard by WNP's radio operator.

This phenomenon was due to the geographic conditions rather than atmospheric electricity. This is the theory advanced by Mix in his attempt to clear up the mystery. He says that the "Bowdoin" was located a few hundred yards north of a 1300 foot cliff which may have acted as a natural barrier to radio signals, creating what is known as a "dead spot." The cliff, according to his explanation, probably shut off signals from the eastern part of the country without being any obstacle to those coming from the western states.

Mix says that the best results were obtained when his aerial was parallel to the cliff in a south westerly direction than when it was placed at right angles to this natural obstruction.

## PUTTING QUALITY

Continued from Page 12

on the apparent quality of the music. If the loud speaker is placed at certain points in the average room, the quality will apparently be effected and the music will become less agreeable. The exact location of these undesirable points, which should of course be avoided, can be found only by experiment, and it is well worth while spending the necessary time with a long cord attached to the loud speaker to determine the proper location of the set before permanently placing it.

A typical ornamental installation of a radio receiver of the cabinet type is

## MacMILLAN PLANS FOR ANOTHER ARCTIC TRIP

Captain Donald B. MacMillan has been back from the Arctic only two months, but he is already planning for another trip North, according to an announcement made during his recent visit to the American Radio Relay League Headquarters in this city.

Next summer the little schooner "Bowdoin" will again head into the ice floes, this time for the purpose of locating a site for a permanent magnetic station in order that observations made by Richard Goddard of the Carnegie Institute on the last expedition may be continued over a period of two years. The following summer, in 1926, Captain MacMillan will install the station permanently.

## Finding Errors in Compass

This observatory will be situated in the vicinity of 54 degrees north latitude, he said, and would undoubtedly be equipped with apparatus for measuring on photographic paper variations in the magnetic needle, which is believed to be swinging westward.

He explained that the advantage of having this station located close to the Magnetic North Pole, is due to the fact that the nearer one goes to the pole, the more pronounced are the deflections of the compass needle as determined by recording apparatus. Variations of only

shown in Fig. 3. Very handsome appearance of the receiver and proper blending with its surroundings can be secured at the same time that the acoustic requirements are met.

## Not Too Close or Far Away

The position of the listener relative to the horn is also of importance. If the hearer gets too close to the loud speaker aside from the excessive loudness of the music, there is a harsh effect. If, on the other hand, the listener gets very much to one side of the horn or behind it, the music will not be loud and will also seem blurred, since much of the sound then gets to his ears by reflection from the walls rather than directly from the loud

speaker. The placing of the hearers at a broadcast concert is not a matter of indifference.

Another effect having indirectly to do with echoes will be discovered if the listener tries the same in a large room and then in a similar, but smaller room. The larger room reinforces and strengthens the deeper notes (lower frequencies), while the small room does not. As a result, it is more difficult to get deep full effect in small rooms unless the loud speaker is designed to take care of this.

## ENGLISH TALK WINS ORANGES

A box of oranges, direct from the Florida groves, recently arrived at Atlanta for R. S. Morris, operator of amateur radio station 410, as a reward for being the first amateur in the fourth radio district to communicate with an English operator. Morris has "worked" three British stations on seven different occasions. The oranges were offered by W. J. Lee of Winter Park, Florida.

## NOW RELAY LEAGUE CAN TALK

There is a new amateur station on the air, 1MK, American Radio Relay Headquarters. The station was installed by F. H. Schnell, traffic manager of the A. R. R. L., following the urgent request of amateurs in various parts of the country. 1MK is equipped with four 5-watt tubes. The farthest two-way communication so far has been with an amateur in Texas.

Broadcast listeners will see from the above discussion why scientific investigation in the entire field of sound has been greatly stimulated by the growth of broadcasting.

# Killing Losses in Condensers

## *Describing What is Meant by a "Low Loss" Unit*

An Interview by SYLVAN HARRIS

WHEN you pick up a magazine you usually run across the term, "Low Loss Condenser" before you have read very far. Just what does this term mean, and why has it sprung into such large use recently?

As now employed by nearly every manufacturer, this description does not mean much of anything. It should and originally did mean that the unit was suitable to use in the circuits with exceptionally sharp tuning where losses, even though small, would cause a

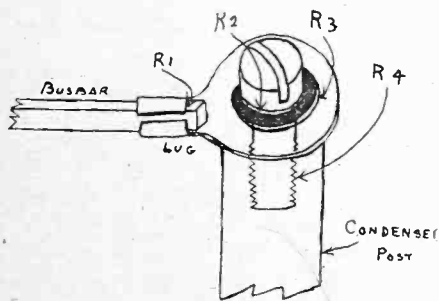

Fig. 1. Conduction Losses Here

decrease in selectivity. The more reliable manufacturers mean just that in their advertisements, but some of the unscrupulous dealers have seized on this term and applied it to any condenser that they wished to sell, whether it fitted or not. Let us see what this phrase really should mean.

### First Find the Losses

Condensers resistance may be outlined as follows:

1. Conductive resistance of plates, contacts, leads, etc.
2. Dielectric Losses:
  - (a) Surface leakage.
  - (b) Volume leakage.
  - (c) Dielectric absorption or hysteresis.
3. Skin-effect in the plates and elsewhere in the condenser.
4. Eddy-currents in metallic parts of condenser.

These items will be discussed in order, and some idea given as to their relative values in determining the resistance of the condenser.

1. *Conductive Resistance*—Every conductor of electricity has resistance, whether it is an ordinary wire or the plates in a condenser. Moreover, every place where two conductors are joined together, as for instance at soldered or clamped joints, has an amount of resistance depending upon how good the electrical contact is between the two conductors which are to be joined. These resistances occur in a condenser in the material of the plates, in the pig-tail connection, in the surfaces in contact between plates and washers, in soldered joints at these places when solder is used, or in the contact between some soft metal and the plates when the plates are set into slots in hollow bars into which the metal is forced under pressure.

This kind of loss is illustrated in Fig. 1, which shows the resistance at four points. R1 is the resistance between the end of the busbar wire and the soldering lug. Since this is covered with solder, the value here will be very low. R2 is the point of contact between the screw head and the washer, R3 between washer and lug, and R4 the resistance from the screw to the condenser post. These last three values will be low if the contact surfaces are clean and no dirt occurs between the parts and furthermore if the screw is set up tight. These resistances are in general very small at low frequencies of the order of 1,000 cycles and will not change considerably with the frequency, but the resistance of the plates themselves will change a great deal with the frequency. This is considered under item 3.

2. *Dielectric Losses*—Dielectric losses are divided into three parts:

- (a) Surface Leakage.
- (b) Volume Leakage.
- (c) Dielectric Absorption.

Surface leakage, as the name describes, is the amount of electricity which runs across the face of the insulator from one terminal to another. If you have a pan of water which is being supplied from a faucet so that it overflows, we get a trickle of water running over the surface as shown at S, Fig. 2. This is the same idea as the electricity leaking over the surface of the insulator or di-

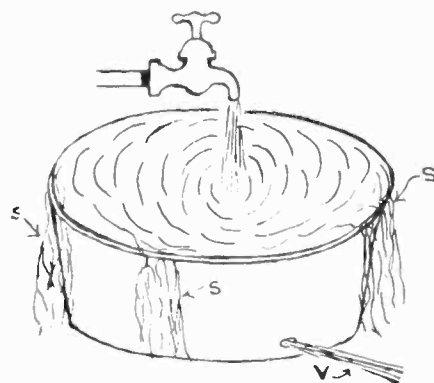

Fig. 2. Two Kinds of Leaks

electric, as illustrated in Fig. 3. If the left hand side of the condenser shown is charged with positive electricity and the right hand side with negative, then there will be a constant current flowing from the positive to the negative along the flat surface and over the edges, which is shown at S. The higher the voltage, or difference in pressure between the + and - the greater the current will be.

This sort of leakage in a condenser is very small indeed unless the plates get covered with some conducting material like moisture or dust. That is why you read that the insulation must be kept clean and dry.

### (b) Volume Leakage

Refer back again to Fig. 2 and you will see that besides the leakage of

water over the surface at S there is also a stream flowing out at V, which comes from the volume of the liquid. This evidently has nothing whatever to do with the surface leakage, which has just

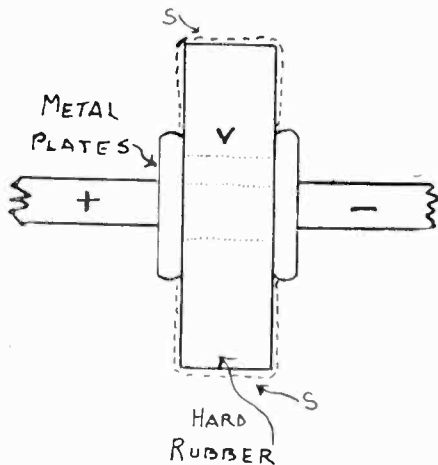

Fig. 3. Surface and Volume

been described. The same thing occurs in Fig. 3 as current leaks right through the mass of hard rubber from the + to the - as noticed at V. This leakage occurs only in solid insulation; that is, there is no loss from plate to plate of a condenser through the air, but the solid ends which separate the stator from the rotor will have some loss from this source, although it will be very small.

In fact, it is a very difficult matter to make a measurable leakage current flow through an ordinary condenser unless very high voltages are used. With ordinary laboratory apparatus the pressure required to obtain measurable leakage currents is almost as high as the spark-over voltage of the condenser, that is, in the neighborhood of four to five hundred volts. It is hardly necessary then, to consider the leakage current that flows through the condenser in an ordinary radio receiver, where the pressures are measurable in microvolts. This takes into account both the surface and volume leakage.

**Insulation is Not Uniform**

Dielectric materials or insulators like bakelite, condensite, hard rubber, etc., are usually assumed to be just alike or uniform all through the mass. But unfortunately they vary somewhat even in the same piece. It is something like a can of paint—even after you have stirred it for ten minutes you will find that it is not alike all the way through, as the top is apt to have more oil and

the bottom more of the solid pigment than the middle. In making up these insulating materials the greatest pains is used to stir them thoroughly, but it is found in practice that slight variations occur even when the mixture is thoroughly stirred. In reality a great number of very small condensers are scattered through it, the plates of these being formed by the different parts of the material which differ in chemical or physical properties.

**Charging a Condenser**

When a condenser is first connected to a source of voltage, there is a rush of current into it, which charges up the plates.

This action takes a very small fraction of a second. For ordinary values the plates will be practically charged with about a millionth of a second or less. Then the *charging current* stops flowing. But it is found by test that *all* current does not stop. A small amount continues. This consists partly of the two kinds of leakages (surface and volume) which have just been described and partly an amount which is absorbed by the dielectric or insulation. The first part just mentioned will continue to flow indefinitely but the latter ceases as soon as all the absorption possible has taken place.



Fig. 4. Testing for Absorption

**Recovering the Absorption**

The fact that it really is absorbed can be easily proved. Suppose you wish to demonstrate that a sponge has absorbed water. The way to do it is to squeeze the sponge and see if water comes out.

(Fig. 4). If you find that you can squeeze out a couple of tablespoonfuls of water into a glass you know that the sponge must have absorbed it. So with the condenser. Disconnect the battery

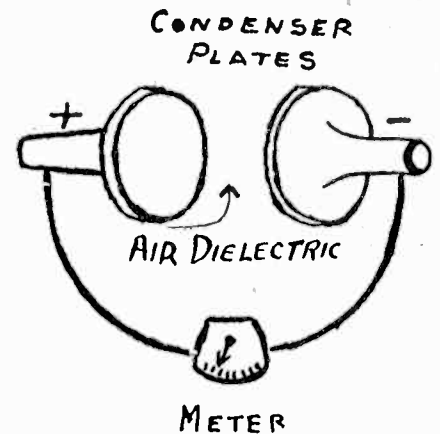

Fig. 5. Dielectric Absorption

which has charged this unit as in Fig. 5, and run a wire from the plus to the minus. This will discharge the condenser as shown by the ammeter. The charge will run out just as fast as it went in. Now break the circuit by taking the wire off. Let the condenser stand for say one minute and again touch the wire. The meter will show a deflection again, then will drop back to zero. This is the amount of current which had soaked into the condenser and now has been squeezed out again.

**How Absorption Varies**

In a condenser having an appreciable absorption a small current (aside from leakage) may continue to flow for a long time after the circuit is closed. This current bears no simple relation to the capacity of the condenser. It depends upon the material of the dielectric, the voltage across its various parts, and the frequency of the current. Obviously the greater the frequency the shorter will be the charging period for the dielectric, and consequently the smaller will be the absorption charge for each cycle. But every time the condenser is charged and discharged the dielectric will have absorbed and squeezed out an amount of electricity. If this occurs only once an hour, it is easy to see that the amount of loss in this way will be quite small. If it occurs once a second, the loss will be considerably larger. And if we charge and squeeze it a million times a second, even though each charge will be con-

siderably less than it was at the slow rate, still the total loss will be considerably higher.

Suppose there is a fire at our summer home and there is no water supply available except what we raise from the well with a bucket. If we work very rapidly and splash the water on as fast as we can, then no one bucket full will be as big as it would have been if we had drawn it slowly and carefully. But owing to the fact that a great many

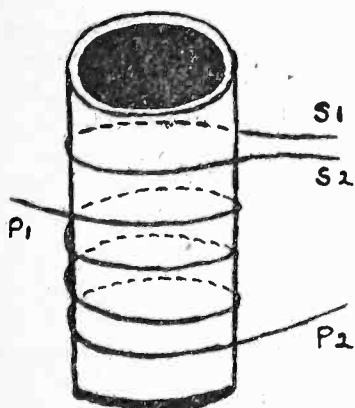

Fig. 6. Eddy Current Losses

buckets full are drawn the total water thrown on the fire will be considerably greater than if we carefully fill each bucket to the top.

3. *Skin-Effect*—This is a phenomenon that has been somewhat neglected by experimenters and designers of condensers. It is generally known that high frequency currents travel in the surface or "skin" of a conductor. There is no reason why this same effect should not be present in condensers. It does exist, and to a very appreciable amount.

**Multiplies Resistance by 20**

Skin-effect in conductors at low frequencies (1,000 cycles or less) is so small as not to be noticed. As the frequency increases, however, the apparent resistance of the conductor, due to this cause becomes very great. In the case of straight wires, it may make the wire act as if its resistance were often as great as 10 or 20 times its direct current (d.c.) resistance. In coils it may be as great as 40 or 60 times the d.c. resistance. Furthermore, the skin-effect is greater, the greater the diameter of the wire.

Skin-effect in flat conductors is less than in round ones of the same area. In flat strips carrying high frequency currents the skin-effect becomes greater as the thickness of the strip is increased.

Although little quantitative work has been described along this line, there is no reason why this effect should not enter into the resistance of a condenser.

4. *Eddy-Currents*—The nature and importance of eddy currents is well known to the power engineer, but the radio fan has, for the most part, forgotten that they exist.

**Eddies Like Neutrodyne**

Eddy currents can be understood by referring to Fig. 6. Here we have a tube with a coil P1, P2 wound on it. This acts as the primary of a radio frequency transformer. On the same tube, spaced a little farther away, is a coil S1, S2, which may consist of only a single turn. This acts as the secondary of the transformer. Of course, a voltage will be induced in this winding by ordinary transformer action, just like what happens in a neutrodyne for instance. Ordinarily the leads, S1 and S2 will run to the grid and filament of the next step of amplifier. But suppose in this case we solder the two ends together and so short circuit the winding. You can easily see that the current will oscillate back and forth in this closed loop just as before, but instead of going out and doing any useful work it will be of no value since it does a ring-around-the-rosy just in its own wire. It is then called an "eddy current."

If, instead of a single turn of wire we had used a metallic disk over the end of the tube, then the edge of the disk, being a conductor, would act just like the wire S1, S2, and we should have an eddy current in the disk. In fact, such a piece of metal would act not only like a single wire at the rim, but also a large number of wires, each circle inside the next, and each would carry eddy currents. That is why such a sheet of metal placed near a coil and especially if it is located right in line with the coil, will cause losses through the waste eddy currents.

**When Magnetism Causes Eddies**

Wherever we have alternating currents we also have magnetic lines of force, or magnetism surrounding the current. If these magnetic lines strike any pieces of metal they will induce eddy currents in them. If the metal is quite small in size the losses will be negligible.

It is certain that some eddy currents will be generated in the metallic structures and end-plates of condensers. The value of the eddy currents depends also upon the resistance of the metal in which they are generated, the strength of the magnetic field, and the frequency of the current to which the existence of this magnetic field is due. For a given material and strength of field, the higher the frequency, the greater are the losses due to the eddy currents.

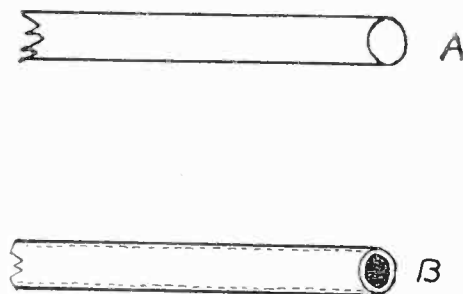

Fig. 7. Skin Effect in Wire

Fig. 7 shows this effect. At A appears a wire of large diameter, which conducts the low frequency current all through its inside. At B is a picture of the same wire, as seen by high frequency currents. Notice that it is now a pipe with thin walls. Of course, as a matter of fact, it is still solid copper as before, but all the electricity flows in the thin tube or skin as shown. Naturally, the resistance runs up tremendously since all the center part of the wire is thrown away as far as the high frequency is concerned.

**Importance of Losses**

Now as to the relative importance of these various items. At very low frequencies, the items contributing to the resistance of a condenser are very small. As the frequency increases, the skin-effect increases, slowly at first, and later very rapidly, as we reach the higher frequencies. Added to this we have the losses due to the eddy currents.

In order to reduce the dielectric loss, many manufacturers are turning to a construction with metallic end plates. Of course, some insulation has to be used to separate rotor and stator. Often times small washers or disks are employed for this purpose. But replacing the dielectric material in a condenser, as far as possible by metallic materials, for the purpose of lowering its

Continued on Page 30



# Fone Fun For Fans

## The Fake

WILLIE HARDCASE—"Maw, that dentist you sent me to that was advertised as painless, wasn't."

MOTHER—"He wasn't?"

"No—I bit his finger, and he yelled just like any other dentist."—*American Legion Weekly*.

## Obstinate

MOTHER—"Now, children, don't quarrel. What's the matter?"

HAROLD—"We're playin' shipwreck, an' Susie won't go in the bathroom an' drown herself."—*American Legion Weekly*.

## Who Knows?

"Pa," inquired his strictly up-to-the-minute offspring, playing with his radio set "what's the wave-length for Santa Claus?"—*Western Christian Advocate*.

## Would a Movie Fan Do?

A woman went into a radio store and said: "I want to buy one of them radio fans I read so much about. My room is awfully stuffy."—*New York American*.

## Jazz Needed

"Has your husband a good ear for music?"

"I'm afraid not. He seems to think that everything he hears played in church is a lullaby."—*Tid-Bits*.

## Lucky Boy

Don't all those papers make you tired?" asked the kindly disposed man of a little newsboy who was struggling along under a huge load of evening papers.

"Naw," replied the newsboy with supreme contempt, "I can't read."—*Ladies Home Journal*.

## It Worked "Fine"

He—"We got a hundred dollar radio set and had the electrician come in and attach it."

She—"That's nothing. We had a five hundred dollar set and the sheriff came in and attached it."—*Enarco News*.

## DO WE WANT RESISTANCE?

Continued from Page 17

best ones are apt to distort, then the poor ones undoubtedly will. (Whatever you do, buy the best transformer). High ratio transformers have sharper peaks than low, and distort more.

Thus in Fig. 7, a good transformer with ratio 3:1 will have a curve A, which falls off a little at the two ends. This shows that the very high notes and the very low ones will not be as loud as those in the middle range, even though the piano playing them is struck just as hard. But the 10:1 transformer is apt to have a much more pronounced

dropping off at the ends of the curve, B. By connecting a high resistance across the secondary as explained, a load is placed on the output and this is found by experiment to pull down the curve in the center more than it does at the ends. Curve C, shows this effect. Of course, the loudness in the middle range has been sacrificed somewhat, but the gain in clearness of speech and music more than makes up for this slight loss.

The improvement in tone quality when an Audiohm is used, is often noticeable, and in ordinary home-made neotrodyne sets, for instance, it will give their owners better quality results. When it is adjusted to the proper resistance for elimination of distortion, your transformer is then working at its maximum quality efficiency, and all surplus energy is being by-passed.

## As a Volume Control

A resistance can also be used advantageously across the phones or loud speaker terminals to control the volume without upsetting the tuning. The resistance in this case is variable from 10,000 to 120,000 ohms also.

There are several other interesting places to use variable resistances, such as across the secondary of radio frequency transformers to broaden the tuning. Also, there is the tremendous big field of resistance amplification. This is so large that I will not attempt to discuss it in this article.

The reader is referred to "Squelching Squeals in an Amplifier" on page 19 of the November 1st issue of RADIO PROGRESS for further light on this subject.

There is also another related field which is being investigated by J. W. T. Marshall of Philadelphia, and that has been fully covered in articles in the Philadelphia Public Ledger of September 20th, 27th and October 4th, under the heading of "Marshall Diode Amplification System." The Diode tube is operated beyond its saturation point and becomes therefore a regulator or balance wheel to maintain the plate current at a constant value.

The real secret of success in the above experiments lies in the fact that resistance coupling and resistances used anywhere do not distort the waves. With inductances and capacities, you are playing with the dangers of distortion, but with resistances, you are simply controlling the energy.

### RADIO PROGRESS

8 Temple St. (P. O. Box 728)  
Providence, R. I.

Date.....

You may enter my subscription to RADIO PROGRESS

for.....year { 1 year \$3.00  
2 years \$5.50

Signature.....

Send it to this address

Paid by (PRINT) .....

Check  .....

Cash  .....

Money order  .....



# EDITOR'S LOUD SPEAKER

## TRACING A HARD ONE

We have requests from our readers to show in some better way the path of the electricity through various circuits in some of the complicated hook-ups. Indeed, it is not easy to trace some of the current paths through the more difficult diagrams of connection.

This request is undoubtedly a very reasonable one. Even the technical radio engineer, who has had a great deal of experience with circuits, finds it difficult to follow the paths through some of the trick circuits that appear in many of the current magazines. And when they have been traced through, they are found to be merely foolish modifications of some standard circuit.

### Following the Waves

In line with this idea we shall, in the future, adopt a scheme (in

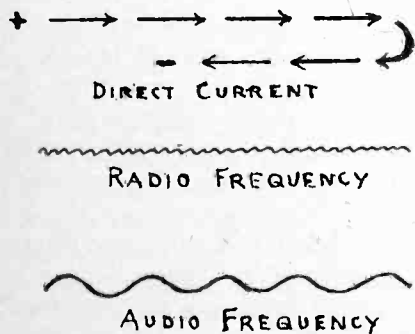

Fig. 1. Symbols of Three Currents

those hook-ups which need it) which will make it much easier to see in what direction the current flows. Direct current is that which flows in one direction only, and will be shown by dotted lines with arrow heads pointing the way in which it goes. Radio frequency approximates one million oscillations per second, and will be illustrated, as in Fig. 1, by a wavy

line with the waves near together. Audio frequency is very much slower—the speed of vibration being from a few hundred to a few thousand a second, depending on the pitch of the note being played. The waves in this case will be spaced farther apart, as indicated in Fig. 1.

In some cases audio and radio frequency both exist in the same wire. For instance, leaving the plate of the detector tube, we find both vibrations existing together. The natural sign for such a condition appears in Fig. 2.

This should not be confusing to any one who has seen a body of water with the wind blowing across it. Take the ocean after a storm, for instance. There are big billows coming in with a distance of perhaps 30 or 40 feet between crests. These represent audio frequency. On top of these waves are ripples which are spaced only a few inches apart. These are radio frequency.

### Adding Direct Alternating Current

Suppose instead of the ocean, we look at the waves in a long narrow bay. In this case when the tide is high (or low) then we have only the two kinds of waves as just mentioned. But at half tide, going in or out, it will be noticed that the whole body of water moves as a unit to fill or

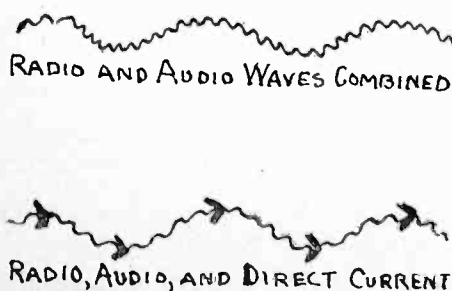

Fig. 2. When Two Currents Add

empty the bay, depending on which tide it is. The high and low frequency waves are still there just the same, but the direct current of water flows entirely independent of them. This may be indicated in the electrical scheme by putting arrow heads in the proper direction on the curve of Fig. 2.

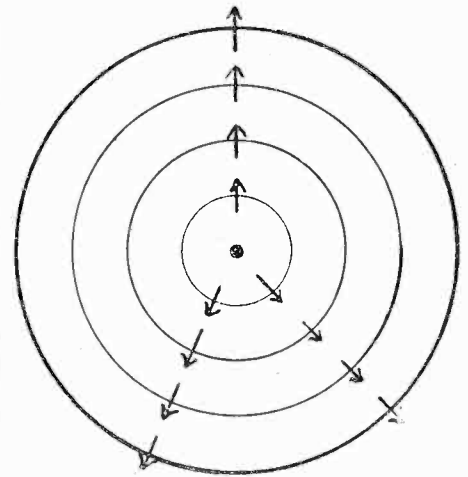

Fig. 3. Waves in Pond

With the direct current, as we have just said, arrows will indicate which way they go. Perhaps some one will ask in which direction the alternating current waves travel. It should be explained here that there are two different kinds of waves.

### Some Travel, Some Stay at Home

Traveling waves are those which start from a certain point and go straight into space. An example of these are the billows of the ocean. They progress in the direction the wind is blowing. A gale, blowing from the North, will kick up big waves and they all move South. When the wind reverses, of course the ocean will not follow immediately, but as

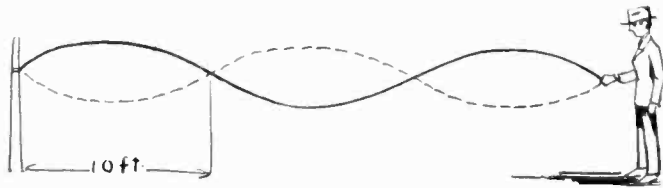

Fig. 4. Common Case of Standing Waves

soon as the old ones have had time to die down, the new waves will be seen to travel right with the wind. Broadcasting stations send out the same kind of oscillations. They start at the sending aerial and travel straight out in all directions. Their course is always in a direct line away from the place where they started. An example of this is seen when a stone is dropped into the water of a smooth lake. A series of ripples, which are circles, are sent out in all directions, and any particular part of the wave travels in a straight line away from the place where the stone struck. (See Figure 3).

The other kind of motion is called the "standing wave." Its motion is seen in a tuning fork. The prongs keep vibrating back and forth continuously, but nobody knows where they started, or where they are going to end up. A spring, with a weight on the end, bobbing up and down, is another example. The wave motion of the spring is seen all through it, but would you say that the waves were traveling up the spring or down? Another case is a clothes line. Suppose we have a thirty foot line, and we shake the end back and forth fast enough so that it divides in three parts. Fig. 4 indicates that the waves are not travelling either to the left or to the right, but each section of rope is oscillating up and down just where it stands. That is why it is called a standing wave.

#### Standing Waves in Set

A general rule is that in space travelling waves will be found, but standing waves usually occur in confined quarters. Since the radio set is quite small, it is standing waves (like the tuning fork) which always occur in its circuits. That is why illustrations like Fig. 1 have no arrows on the alternat-

ing current drawings. In other words, the waves do not move to the left nor to the right, but oscillate back and forth, first in one direction, and then in the other.

#### MOSTLY ALL BOSH

In reading many of the radio publications to-day, it is surprising how much nonsense you run into. Of course, this is a new science, and most people have not had the time to study into it as deeply as they might wish. A great many of the writers trade on this situation and try to get away with a lot of tommy-rot.

Radio is largely a matter of common sense. There are some rather obscure details in the operation of many parts but in the main, a little thought on the part of any intelligent person will enable him to understand how the set works in all important parts. And when you get right down to it, isn't that about all you can say for most anything? Take the wind for instance. Everybody understands that pretty well. But when you get down to details, can you explain why, in the middle of the open lot, a pile of leaves will suddenly swirl around and around? If you think you can explain this, then tell whether they will turn to the right or to the left, and why.

#### The Mystery of Radio

Coming to radio the same thing applies. If you want to dig up a reason for all the small details, you will find it difficult to get the answer to many questions. But all the main actions in the set can be followed just as you can comprehend the action of the wind on a windmill. The "mystery" of radio is pretty well cleared up, if you will read any good radio magazine for a few months.

When you come across an article which seems to use a great many technical words in a rather

random fashion, and which seems to mean nothing to an intelligent person, it is about ten to one that it really does mean nothing. We are not talking about radio alone, but about any subject.

For instance, suppose on the financial page of a newspaper you should read something like this, "Securities rose rapidly yesterday, because of the high rate of interest on the depreciation of the bonds. The call rate on foreign exchange was very arbitrage." You would know right away, even if not a financial expert, that something was wrong, and that it was all bosh. In the same way there are a great many articles appearing on radio.

Here is a quotation from the middle of a very good article, which shows how even a good man can write when he wants to appear to know more than the reader.

#### Can You Follow This?

"By feeding through the shunt circuit, a very small portion of the plate current to the secondary of the second stage transformer, it is then 180 degrees out of phase with the distorted impulses communicated through the transformers, which therefore nullifies the distortion. Should a greater amount of current be by-passed than is necessary to eliminate the distortion, the lower frequency impulses will be connected across the shunt path and reduce the volume of amplified impulses that come through the transformers normally."

The author of the above lines is a well-known engineer, and must have had something in mind, but we defy any one to understand what it was. Many of the write-ups which are now appearing are even a lot worse than this.

There is no easy way of picking out the worth while articles from the pot boilers. However, it is a pretty good rule that whenever a writer begins to talk in high flown language, using a lot of words apparently to confuse the reader, it is safe to say that in general he does not know what he is talking about.

# A "Mike" That Will Not Wait

## *New Station Has Several Unusual Points of Interest*

**R**ADIO engineers and surveyors selected Harrison, Ohio, as the ideal place for the new powerful radio broadcasting station of the Crosley Radio Corporation. By locating this up-to-date new WLW transmitting station twenty-five miles from the new studios in Cincinnati and away from thickly populated districts the company has made sure that it will not interfere with the majority of radio fans. Maps showing how the population is distributed were prepared before the final selection was made for the station. Fans will find tuning to the new powerful Western Electric equipment at Harrison extremely sharp as the result of using the very latest apparatus developed for radio broadcasting.

Either telephone or telegraph wires may be used to connect the station with the studios which are in the city, twenty-five miles from the point of transmission. Such a high-powered station requires a vast amount of special construction for the electric service, and all special lines necessary are being installed.

### No Hills to Obstruct

From the site of the new station on a high knoll, views may be had of Hamilton, Lawrenceburg, Cincinnati, Middletown and other places. The station with its two 200-foot towers will be the highest point in any of the surrounding country, and the absence of hills or forest is extremely advantageous because there will be no loss of power through absorption.

When a transmitting station is located on an office or factory building, there is a tremendous amount of absorption by lighting wires, sprinkler system, smoke stacks and steel frames in the building. In the present location of WLW, a change can be noticed in the radiation every time the telephone call system is put into operation. In the country where the new station will be located, there will be no change in antenna conditions from season to season.

A system of ground wires is being buried under the four hundred foot antenna, and trees, shrubbery or other things to absorb energy will be missing. Vegetation will be kept cut down beneath the aerial wires, thus reducing the resistance to the high frequency currents which must flow into the ground under the antenna.

### Where Drums Are Not Heard

A pick-up amplifier with the monitor control will be installed in the Cincinnati studio, and a similar amplifier will be used at the station itself. These amplifiers, which have just been developed, give a reproduction of voice and music which is thought to be even more faithful than the justly famous present type of Western Electric amplifier. It has often been observed that such instruments as the drum are transmitted very poorly by practically all broadcasting stations. The very low notes of the pipe organ are also difficult to put on the air properly. The design of the new amplifier makes it possible to hear these instruments as never before, and faithful reproduction is assured.

Automatic control will be used at the studio. Only a few seconds after the master control button has been pressed by the studio operator, the transmitting set twenty-five miles away will be in operation. The transmitter itself will be enclosed in a metal cage, so that it will be impossible for the operator to touch any of the high voltage transformers, etc., without first opening a door which automatically turns off the high voltage. The generators, however, which are located in an adjoining room, continue to run, so that the set may be shut off for just an instant to make quick adjustments, and put on the air again with a minimum loss of time.

### What if the Water Stopped?

The power amplifiers referred to use ten thousand volts potential on their plates, which is supplied by means of

three powerful rectifying tubes which operate on ten thousand volt alternating current. These power tubes and rectifiers generate so much heat in their operation, that the plates are jacketed and cooled by water. Automatic devices are provided which will give warning if the cooling water for the high power tubes ceases to flow, or a filament of one of the rectifiers or amplifiers burns out.



Fig. 1. Using Quick-Change Mike

Of course you remember the old lantern slide in the movie theatre which asked you to wait a moment while the reels were changed? And the "One moment please," from the broadcasting studios while the artists were preparing for the next number? Well, the new stands in the studio do away with any wait between numbers. The familiar red signal light is no more. In its place the engineers have developed something new. Upon a small circular stand rests the

Continued on Page 26



# Making a Good Operator

(By Walter C. Evans, Chief Engineer Westinghouse Electric & Manufacturing Company, Broadcasting station KYW.)

There are two general classes that make good operators. The first is the graduate electrical engineer who has learned enough about radio to obtain a Government license. The other is the old-time radio operator who has passed the experimental or "bug" stage, and with whom radio is a serious means of earning a living.

The work in each particular radio station is vastly different from that in any other, so it is more desirable to start a new man who is green as far as broadcasting is concerned, and to train him to specialize on a particular equipment in the station in which he is to operate. The ex-amateur operator is apt to be too inclined to experiment according to his own idea and obviously this does not work out well in a station which operates 24 hours a day. The dyed-in-the-wool telegraph operator seldom becomes sufficiently interested in the electrical or mechanical end to be very valuable. The operators who have had one or two years of sea service have had just enough experience to make it difficult to teach them the game from the very beginning.

## How to Break in

First of all, a prospective operator must hold a Government license—this is required by law. In addition to this, he must have a good working knowledge of the electrical trade, so that he may be able to overcome difficulties which may arise within the equipment. He must be ingenious, able to think fast in emergencies, and to segregate and overcome troubles. He must have a good personal appearance and pleasant personality, so he may successfully meet people when outside pick-ups are used. It is desir-

able that the applicant also be a good Morse wire operator, because most of the better stations use land line telegraph for orders between the point of pick-up and the radio station. Commercial telegraph wires are now looped through broadcasting stations, so that the artists may get their applause card messages first hand, and it is a convenience if the radio operators are able to handle these messages.

In brief, the applicant should be a diplomat, technician, telegraph operator, steeple jack, public contact man and, on top of that, husky enough to carry storage batteries. In fact, a successful radio man must be nearly everything but a cook.

## Where They Come From

Four of the engineer-operators at Westinghouse station KYW, are graduate engineers, who have also acquired considerable radio experience in the U. S. Navy, and with commercial radio companies. Five have been borrowed from the ranks of merchant-marine wireless operators, and have developed sufficient knowledge of the mechanics of the equipment to make themselves valuable—the balance are ex-amateurs far enough removed from their experimental days to be good consistent operators.

The present supply of radio operators does not nearly meet the demand of the large number of new broadcasting stations. The field of radio operators and kindred pursuits is especially attractive with its rapid increase in popularity, and these young men whose ambitions follow that channel should give first thought to the requirements just described.

## FREE MUSIC LESSONS

A new method of acquiring a musical education has been discovered by a radio fan living in a small town just outside of Springfield, Mass. Said fan has a profound musical appreciation and not only listens to the concerts from Westinghouse Station WBZ but also helps herself acquire additional music learn-

ing. The stunt is explained as follows. The fair fan plays the piano "a little bit," so she confesses. While the concerts are going on she opens a music book and follows the pieces along as they are being played. "This is very helpful for a person who is taking music lessons," she adds. WBZ has not as yet declared its intention of charging fees for such a musical course.

## MIKE WILL NOT WAIT

Continued from Page 25

microphone, but in the stand there is a system of illuminated signs to inform the artist when to "Prepare," and when to "Broadcast." By illuminating these signs automatically, the voice of the announcer or artists is carried into the air by the turn of a switch. No longer will it be necessary to ask the audience to "wait a minute" while one artist prepares for his turn following that of a fellow broadcaster, for the two studios have done away with this. A demonstration of the rapidity of this system was made on the night of the dedication, when twelve pieces were given from both studios without a loss of a second between them. Fred Smith, studio director, is shown in Fig. 1 using one of these new microphones. He holds a pamphlet describing Ido or Ilo, the new radio language.

## Auditorium is Interesting

One finds a combination of the old world and the new as he enters the auditorium which is joined to the two studios. A partition of plate glass divides the auditorium from the solo and ensemble studios, with swinging doors at each end for the use of the artists who broadcast. The visitors remain in the auditorium where two amplifiers, connected with the broadcasting equipment, permit the work of the artists to be heard.

Rough finished walls and ceiling with indirect lighting and skylight, together with a special ventilator, make the auditorium comfortable. On the rear wall hangs a large tapestry from France, while on each side wall is a tapestry of ancient design. Two antique chests and a bench are at the rear of the auditorium, while two large Italian mirrors are hung on the wall.

A RELIABLE and thoroughly experienced radio manufacturing and merchandising organization wants live-wire representative in your community. Complete line of highest quality receiving sets and accessories, exclusive territory, and liberal discounts without annoying quantity regulations. Write or wire Radio Development Co., 25 S. 13th St., Harrisburg, Pa.

# Sending Station Stories

## Does Hyena Really Laugh?

Multitudes of people are unfamiliar with the habits of wild animals and know them only through books. That is why they have many mistaken conceptions as to the degree of their wildness; few folks actually know how ferocious some of nature's pets really are. Thornton W. Burgess, nationally-renowned writer of stories for children and a naturalist of recognition, contends that for the sake of truth, a group of theories about wild animals ought to be exploded. Through arrangements completed with station WBZ at Springfield, Mass., he will appear at the Hotel Kimball studio of that station every Wednesday night to expose some of the false impressions about so called ferocious beasts. He has already given a talk on wolves in which his experiences in desolate open countries of the far north were recounted and many interesting comments about the wolf, who is supposed to be a treacherous animal, were passed by the naturalist.

All of Mr. Burgess' talks will be given during the children's period from the Springfield studio and the language employed will bring the stories to the children's level. A semi-story form will be used throughout, so that the little ones will not think they are being submitted to a school lesson. During the course of his talks, the speaker will introduce and describe some of his animal friends, of whom he has written so much, and many surprises are in store for the youngsters. Wednesday nights at WBZ will be set aside as "Thornton W. Burgess Night," and an elaborate program for the wintry nights is being planned by this famous story writer and naturalist.

Those who know little about nature and its creatures will learn a great deal from Mr. Burgess. Information which Mr. Burgess has never disclosed will be flashed into the air for radio tuners on his Wednesday night appearances, materials which were gathered on a recent hunting and observation trip Mr. Burgess made in the Canadian woods. Little can be said of the surprises promised for

the kiddies at this time, but it is safe to say that many a little one will get lots of fun out of some of the stunts.

## A FINE ARTS COURSE

The first of Westinghouse Station's educational courses, many of which were radioed so successfully last winter, is now under way, and at the present time courses in Modern American Literature and Appreciation of Music are being broadcast. They are being put on the air from the Herald-Traveler-West-



Prof. Robert E. Rogers

inghouse studio, Hotel Brunswick, Boston, in co-operation with the Commonwealth of Massachusetts, Department of Education. Robert Rogers, professor of English literature at the Massachusetts Institute of Technology, will conduct the course in Modern American Literature and will deliver the lectures. His course started in November, and lectures will be given every Monday night at 7:30 o'clock. Professor Stuart Mason, of the New England Conservatory of Music will conduct the Musical Appreciation Course, similar to the one broadcast by Westinghouse WBZ last spring. His lectures will be radioed every Friday

evening from Boston, for eight consecutive times, at 7:30 o'clock.

Prof. Rogers is an associate professor of English at M. I. T., in Cambridge. He is also a lecturer in the Sargeant School of Physical Education in Cambridge, the School of Expression, Pierce Bldg., Boston, and is a member of the University Extension faculty. He is a former member of the Boston Drama League.

## LET THE CHILDREN HEAR THESE

The Museum of Natural History has arranged to present from WEAF on alternate Friday afternoons a series of talks to be given by their lecturers. The titles show that a good deal of thought has been given to the selection of topics which will appeal to children of school age as well as grown-ups.

Mr. Sherwood is acting director of the department of education of the museum, and his work brings him in close contact with the leading educators of the country. This helps him in supplying talks of interest to children.

Here is the program arranged by the American Museum of Natural History to be heard from WEAF:

Dec. 5—Nature's Lullaby-land, Grace F. Ramsey.

Dec. 19—Indian Stories—Princess Chinquilla.

Jan. 2—Arrival of Jack Frost—Grace F. Ramsey.

Jan. 16.—The Mermaid and the Star, Ruth C. Noble.

## FARMERS KNOW A GOOD THING

It is estimated by the United States Department of Agriculture that more than 370,000 radio sets are in use on farms, as compared with 145,000 a year ago. This indicates the farmer appreciates the radio and the service it renders him.

# New Products of Unusual Interest

## A VERNIER CONDENSER WITH VERY LOW LOSSES

Many condensers on the market at the present time have two troubles—their losses are high enough to prevent sharp tuning and the bearings are so loose that the plates rock slightly. A condenser that we have recently tested, the Crowfoot, gets rid of both these difficulties. It uses no end plates at all so there is no question of losses there. A glance at Fig. 1 will show that the insulation between rotor and stator consists of three hard rubber buttons

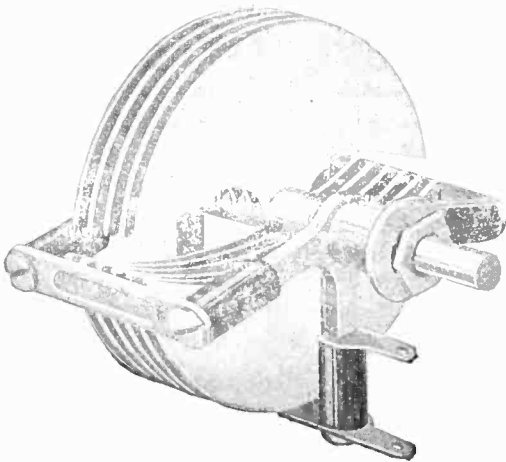

Fig. 1. A Good Low-Loss Condenser

at each end. The amount of insulation is so small that the losses are quite low.

The bearings, instead of passing through an ordinary drilled hole, are made up of cones, which are adjusted by a screw in the end. This prevents side play and makes so rigid a bearing that a vernier dial can be used which converts the unit into a vernier condenser. When used with an "EZ Tune" vernier dial it was found that even on a sharp tuner the whistle from a distant station could be raised and lowered in tone with great smoothness.

This instrument has an unusually low capacity when turned to the "out" position. For instance, in the .0005 mfd size the zero capacity drops to 1/74th of the "full on" value. This result is obtained partly by omitting the end plates and partly by the peculiar crescent shape of the plates. The stator plates are cut away so that they do

not come very close to the rotor shaft. This can be seen in the illustration. Like many of the modern condensers, only a single hole in the panel is needed to mount this unit.

## USING LOOP OR AERIAL

Continued from Page 7

wire, using 50 turns. It is connected to the jack springs, so that when the plug is withdrawn (Fig. 5) the leads run to the grid and the filament of the first amplifier tube.

As a further refinement on this scheme where the utmost in distance is wanted, it is possible to use a variometer in series with a primary for tuning it to the incoming waves. It should be connected in the ground lead at the point G on the coil. By adjusting this variometer, the primary can be brought into resonance with the incoming wave. This will give the largest amount of current possible in the primary circuit, and of course this will increase the volume in

means that you will have to shorten the aerial still more in order to get good results. Such a use of the variometer causes increased complication on the set, and makes one more handle to adjust, and since the gain will not be very large anyway, it is usually not recommended.

## Changing From Aerial to Loop

If you already have a set which works on an outside aerial, you are probably interested in the method of making it work on a loop. Unfortunately, there is no simple means of making this change. Owing to the small amount of energy picked up by the latter, it is absolutely necessary to use at least two steps of radio frequency amplification ahead of the detector to get good signals. And even at that, a radio like the neutrodyne, which is not designed for it, does not usually work very well on a loop, even though it does use two tubes of radio amplification.

The only kind of sets which are reported as being very successful without

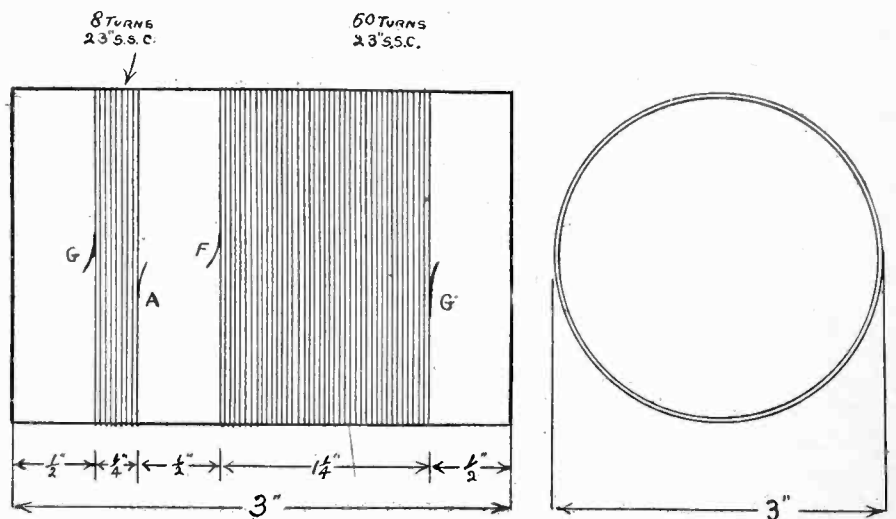

Fig. 8. How to Wind Aerial Transformer Coils

the secondary. Since such a variometer always increases the effective length of the aerial, you must be careful not to start with one that is already too long. For such use the total length, including the lead-in, should not run much over 100 feet. If you find, when listening to a short wave station, that the signals get louder and louder as you turn the variometer towards the zero, then it

an aerial, are those which have two or three steps of untuned radio amplifier, and those which make use of the super-heterodyne principle. These, of course, have to be built from the ground up, and cannot be adapted very well from other styles of hook-ups. To those who ask how to change from an ordinary set using an outside aerial so that it will work on a loop our advice is "Don't."

# R DR RADIO PRESCRIBES.

**NOTE:** In this section the Technical Editor will answer questions of general interest on any radio matter. Any of our readers may ask not more than two questions, and if the subjects are of importance to most radio fans they will be answered free of charge, in the magazine. If they are

of special interest to the questioner alone, or if a personal answer is desired, a charge of fifty cents will be made for each answer. This will entitle the questioner to a personal answer by letter. However, if the question requires considerable experimental work, higher rates will be charged.

**Question.** Why do some dials have the numbers run from zero up while others start at 100 and run down?

**Answer.** This is more a question of taste than anything else. Either way is all right, provided you are used to it. Since we read from left to right, while the Chinese read things backwards, it would seem reasonable to use the dials which run from zero to 100, rather than the others. We have found by trial that many new comers to the art cannot realize that say 41 comes before 40 on one of these left hand dials and is apt to read it 39. That is why we prefer the dials which read in the natural order rather than those which are backwards.

**Question.** Which is better for connecting a loud speaker, a jack or binding posts?

**Answer.** It makes no difference in the operation of the set which is used. If it is likely that the speaker is to be changed from time to time then it is more convenient to use a jack, as this can be snapped in and out in an instant. The binding posts are not as neat looking, either, but the cost is considerably less than that for a jack and a plug to fit.

**Question.** I have a two variometer single tube set, in which the regeneration is hard to control. How can this be built over to use a variocoupler?

**Answer.** The two variometer hook-up is shown in Fig. 1. The first of these units is employed as a tuner for the input, while the second one is hooked up in the plate circuit to control the amount of feedback or regeneration. As you say, the control of this action is not very satisfactory with this hook-up. To change the set over, it will be necessary

to use a variocoupler with the stator as a secondary and the rotor as the tickler coil. Fig. 2 shows the customary method of making this change. Notice that as far as the rest of the circuit is concerned, everything is the same except for the omission of the two vario-

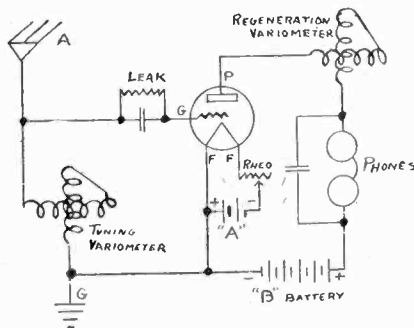

Fig. 1. Set Hard to Work

eters and the substitution of the variocoupler. The coarse tuning of the primary is accomplished by picking out one or another tap on the stator. This can be conveniently done by a tap

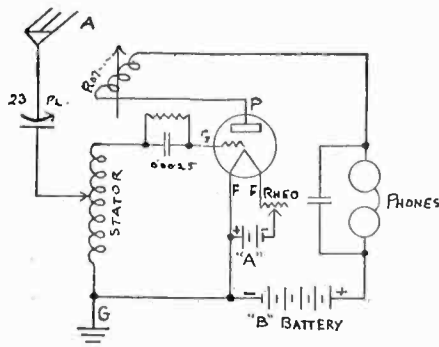

Fig. 2. Rebuilt Hook-up

switch. A 23-plate variable condenser is connected in the aerial lead, as shown, to get the fine tuning. This set is very simple to operate. The condenser and tap switch pick out the station, and the

variocoupler controls the feedback. However, there is the serious disadvantage that it is a bad squealer unless you operate it properly. To do so, be sure that the feedback is not turned up to the place where it begins to oscillate.

**Question.** Can a rheostat be used for fine tuning?

**Answer.** In some sets the rheostat can be used to shift the wave length slightly in tuning. However, we do not advise such operation. The rheostat is designed with only one purpose in mind—that of controlling the voltage on the filaments. For this purpose it is perfect. If the setting is such that the tube gets rated voltage (5 volts for 200 and 201A, and 3 volts for UV-199) then it should be left in that condition without further change. If it is turned higher to adjust the tuning, then the life of the bulbs will be needlessly shortened. On the other hand, if it is turned lower it will result in decreased efficiency of operation in the tubes. The control for tuning to the proper station is the variable condenser or variometer in the grid circuit, and if this is correctly designed, that is all that is necessary. If you find difficulty in getting accurate control, then use a vernier condenser or variometer, or change your dial for one which gives very fine vernier control like the "EZTune" or the "Accuracy."

**Question.** I see in the various radio journals that such and such a set will pick practically any station in the U. S. just by turning the dials. Is this true?

**Answer.** To read some of these advertisements would lead you to think it was an easy matter to pick up any station at any time. As a matter of



fact, all good sets are subject to the same trouble—that of interference from static and from squeals of nearby radiating sets. When these two get to be too bad, it is impossible for any set to get good results on very distant stations. Furthermore, to get sharp and accurate tuning requires a good deal of experience. We have worked with a great many different makes of radio, and we find that it takes nearly as long to learn to turn a dial correctly as it does for a beginner to learn to steer an automobile straight. This applies to all makes of radio, and to all makes of automobiles.

*Question.* What causes tubes to get bad after being operated for some time?

*Answer.* There are three separate causes which make a good tube go bad.

The first and most evident one is that the filament is burned out from too high a voltage. Of course, that can not be cured. The second is that the filament is no longer in good shape. This may be caused by old age or by a long continued forcing of the tubes by using a pressure on the filament a little bit higher than what it was designed for. It results in burning off the coating. If the tube is WD-11 or WD-12, then the case is hopeless. Local stations will come in fairly well, but no distance will be received. If the tube is a UV-201A or UV-199, it may be restored to receive about as well as when it was new by a treatment which is called "Reactivation." This consists in burning the filament at a slightly higher temperature than normal with the "B" battery disconnected. This was described at

length in the August 1, 1924 issue of RADIO PROGRESS.

The third trouble which happens to tubes is the gradual decrease in the vacuum. This is apt to happen in any tube even though the vacuum may have been perfect at the start. It also results in a gradual decrease of the loudness of distant stations, until finally they cannot be heard any more. The only test to make sure whether the tube is at fault, is to connect a milliammeter in the plate circuit, and compare the current with that obtained on the same circuit with a tube that is known to be good. If the suspected tube takes the same amount of current, then you can be sure that it is all right, but if the meter reads only one-half or two-thirds what it does with the good tube, then you will know that its useful life is past.

**KILLING LOSSES**

Continued from Page 21

resistance, may not always bring the results that are desired. What is gained in the way of reducing dielectric absorption may be more than over-balanced by what is lost in the way of eddy-currents. This, in fact, may be very pronounced, as we go toward the ultra-short wave lengths, for it must be re-

membered that eddy-current losses and skin-effect go up rapidly with the frequency.

This is not an argument in favor of one type of end-plate over the other. At any rate, this is not the most important part of the argument. Skin-effect in coils is perhaps more important than all the other losses. It should not be neglected in connection

with condenser. In attempting to design coils having the lowest resistance possible, the size of the wire to be used is important. It seems, therefore, that the thickness of the plates in a condenser may have a serious effect on its resistance. If the plate is too thin, its d.c. resistance becomes high; if it is too thick the eddy currents may get to be excessive. This suggests an important field for research, for those who are able to measure accurately the resistance of air condensers.



**IT'S LUCKY FOR BROADCAST BILL THAT THEY SIGNED OFF**

Broadcast Bill likes visitors,  
They brighten up his life,  
So last night they had company,  
The doctor and his wife.

The radio brought in some jazz,  
"Let's dance," said Mrs. Bill,  
unless the station has signed off  
They'd be there dancing still.

By Del.

**UNCLE SAM BUYING RADIO**

A committee on Radio Apparatus has been formed by the Federal Specifications Board. This committee will adopt standard specifications for use in purchase of radio equipment by all Government Departments.

**Wide Breach**

Judge—"Have you good grounds against this man for your breach of promise suit?"

Liza—"Deed Ah has! Ah promised mahself to marry dat man, an' he ain't nevah asked me to." —*Bursts and Duds.*

**Free Mailing Lists**  
Will help you increase sales  
Send for FREE catalog giving counts and prices on thousands of classified names of your best prospective customers—National, State and Local—Individuals, Professions, Business Concerns.  
**99% Guaranteed 5¢ each**  
by refund of 5¢ each  
**ROSS-Gould Co. 612N. 10th St. St. Louis**

**UNITED STATES BROADCASTING STATIONS  
ARRANGED ALPHABETICALLY BY  
CALL LETTERS**

Abbreviations: W.L. wave length in meters; K.C., frequencies in kilocycles; W.P., watt power of station.

W.L. K.C. W.P.

KDKA	Westinghouse Elec. & Mfg. Co., East Pittsburgh..	326-920-1000
KDPM	Westinghouse Elec. & Mfg. Co., Cleveland, O....	270-1110-250
KDPT	Southern Electrical Co., San Diego, Cal.....	244-1230-100
KDYL	Salt Lake Telegram, Salt Lake City, Utah.....	360-833-100
KDYM	Savoy Theatre, San Diego, Cal.....	280-1070-100
KDYQ	Oregon Institute of Technology, Portland, Ore...	360-833-100
KDZB	Frank E. Siefert, Bakersfield, Cal.....	240-1250-100
KDZE	The Rhodes Co., Seattle, Wash.....	270-1110-100
KDZF	Auto. Club of So. Cal., Los Angeles, Cal.....	278-1080-500
KFAD	McArthur Bros. Mercantile Co., Phoenix, Ariz...	360-833-100
KFAE	State College of Washington, Pullman, Wash....	330-910-500
KFAF	Western Radio Corp., Denver, Col.....	360-833-500
KFAJ	University of Colorado, Boulder, Col.....	360-833-100
KFAQ	City of San Jose, San Jose, Cal.....	360-833-250
KFAR	Studio Lighting Service Co., Hollywood, Cal....	280-1070-150
KFAU	Boise High School, Boise, Idaho.....	270-1110-150
KFBB	F. A. Buttrey & Co., Havre, Mont.....	360-833-100
KFBK	Kimball-Upson Co., Sacramento, Cal.....	283-1060-100
KFCF	Frank A. Moore, Walla Walla, Wash.....	360-833-100
KFCL	Los Angeles Union-Stockyards, Los Angeles, Cal.	236-1270-500
KFCM	Richmond Radio Shop, Richmond, Cal.....	360-833-100
KFCZ	Omaha Central High School, Omaha, Neb.....	259-1160-100
KFDH	University of Arizona, Tucson, Ariz.....	360-833-150
KFDM	*Magnolia Petroleum Co., Beaumont, Texas.....	306-890-500
KFDX	First Baptist Church, Shreveport, La.....	360-833-100
KFDY	So. Dakota State College, Brookings, So. Dakota	273-1100-100
KFEL	Winner Radio Corp., Denver, Col.....	254-1180-100
KFEQ	J. L. Scroggin, Oak, Neb.....	268-1120-100
KFEX	Augsburg Seminary, Minneapolis, Minn.....	261-1150-100
KFFV	Graceland College, Lamoni, Iowa.....	280-1070-100
KFFY	*Louisiana College, Alexandria, La.....	275-1090-100
KFGC	Louisiana State University, Baton Rouge, La....	254-1180-100
KFGH	Leiland Stanford Jr. Univ., Stanford Univ., Cal.	273-1100-500
KFGJ	Mo. Natl. Guard, 138th Infantry, St. Louis, Mo.	265-1130-100
KFGK	First Presbyterian Church, Orange, Tex.....	250-1200-500
KFGZ	Emmanuel Missionary Col., Berrien Sprrs., Mich.	268-1120-250
KFJH	Fallon & Co., Santa Barbara, Cal.....	360-833-100
KEHR	Seattle, Wash.....	263-1140-100
KFPL	Dublin, Tex.....	252-1190-
KFI	Earle C. Anthony, Inc., Los Angeles, Cal.....	469-640-500
KFIF	Benson Polytechnic Institute, Portland, Ore....	360-833-100
KFIX	*R. C. of Jesus Christ of L.D.Stas., Ind'p'nd'n'e, Mo.	268-1120-250
KFIZ	D'ly C'm'nw'h & Seifert Radio C'p., Fond d'L'c, Wis.	273-1100-100
KFJC	Seattle Post Intelligencer, Seattle, Wash.....	270-1110-100
KJFE	*Oklahoma, Okla.....	261-1150-225
KJFK	Delano Radio and Electric Co., Bristow, Okla....	234-1280-100
KJFM	University of N. Dakota, Grand Forks, N. Dak...	280-1070-100
KFKB	Brinkley-Jones Hospital Association, Milford, Ks.	286-1050-500
KFKQ	Conway Radio Laboratories, Conway, Ark.....	250-1340-100
KFKX	Westinghouse Elec. & Mfg. Co., Hastings, Neb....	291-1030-1000
KFLV	Swedish Evang. Mission Church, Rockford, Ill....	229-1310-100
KFMQ	University of Arkansas, Fayetteville, Ark.....	263-1140-100
KFMX	Carleton College, Northfield, Minn.....	283-1060-500
KFNF	Henry Field Seed Co., Shenandoah, Iowa.....	266-1130-500
KFOA	The Rhodes Co., Seattle, Wash.....	454-660-500
KFPT	The Deseret News, Salt Lake City, Utah.....	360-833-500
KFOB	Search Light Publishing Co., Fort Worth, Tex....	254-1180-100
KFOC	Kidd Brothers Radio Shop, Taft, Cal.....	227-1320-100
KFQD	Chovin Supply Co., Anchorage, Alaska.....	280-1070-100
KFOU	W. Riker, Holy City, Cal.....	234-1280-100
KFOV	Omaha Grain Exchange, Omaha, Neb.....	231-1300-100
KFOX	*Alfred M. Hubbard, Seattle, Wash.....	233-1290-500
KFQZ	Taft Radio Co., Hollywood, Cal.....	240-1250-250
KFRB	Hall Brothers, Beeville, Tex.....	248-1210-250
KFSG	Echo Park Evangelistic Ass'n, Los Angeles, Cal...	234-1280-500
KGO	General Electric Co., Oakland, Cal.....	312-960-1000
KGU	Marion A. Mulreny, Honolulu, Hawaii.....	360-833-250
KGW	Portland Morning Oregonian, Portland, Ore....	492-610-500
KHJ	Times-Mirror Co., Los Angeles, Cal.....	395-760-500
KHQ	Louis Wasmer, Seattle, Wash.....	360-833-100
KJR	Northwest Radio Service Co., Seattle, Wash....	270-1110-100
KJS	Bible Institute of Los Angeles, Los Angeles, Cal.	360-833-750
KIS	Warner Brothers, Oakland, Cal.....	360-833-250
KIX	Tribune Publishing Co., Oakland, Cal.....	508-590-500
KLZ	Reynolds Radio Co., Denver, Col.....	283-1060-250
KNT	Grays Harbor Radio Co., Aberdeen, Wash.....	263-1140-250
KNV	Radio Supply Co., Los Angeles, Cal.....	254-1180-100
KNX	*Los Angeles Express, Los Angeles, Cal.....	337-890-500
KOB	N. M. C. of Agri. & Mech Arts, State Col., N. M.	360-833-500
KOP	Detroit Police Dept., Detroit, Mich.....	286-1050-500
KPO	Hale Bros., San Francisco, Cal.....	422-710-500

W.L. K.C. W.P.

KQV	Doubleday-Hill Electric Co., Pittsburgh, Pa.....	280-1070-500
KSD	Post Dispatch, St. Louis, Mo.....	545-550-500
KTW	First Presbyterian Church, Seattle, Wash.....	360-833-750
KUO	Examiner Printing Co., San Francisco, Cal.....	360-833-150
KUS	City Dye Works & Laundry Co., L. Angeles, Cal...	360-833-100
KWG	Portable Wireless Tel. Co., Stockton, Cal.....	360-833-100
KWH	Los Angeles Examiner, Los Angeles, Cal.....	360-833-500
KYQ	Electric Shop, Honolulu, Hawaii.....	288-1040-100
KYW	Westinghouse Elec. & Mfg. Co., Chicago, Ill....	535-560-1000
KZM	Preston D. Allen, Oakland, Cal.....	360-833-100
WAAB	Valdemar Jensen, New Orleans, La.....	268-1120-100
WAAC	Tulane University, New Orleans, La.....	360-833-100
WAAF	Chicago Daily, Drivers Journal, Chicago, Ill....	286-1050-200
WAAM	I. R. Nelson Co., Newark, N. J.....	263-1140-250
WAAW	Omaha Grain Exchange, Omaha, Neb.....	360-833-500
WAAZ	Hollister-Miller Motor Co., Emporia, Ks.....	360-833-100
WABI	Bangor Ry. & Elec. Co., Bangor, Me.....	240-1250-100
WABL	Conn. Agri. College, Storrs, Conn.....	283-1060-100
WABM	F. E. Doherty Auto. & Radio E. Co., Saginaw, M.	254-1180-100
WABP	Robert F. Weinig, Dover, Ohio.....	265-1130-200
WABU	Victor Talking Machine Co., Camden, N. J.....	225-1330-100
WABX	Henry B. Joy, Mount Clemens, Mich.....	270-1110-500
WAHG	A. H. Grebe & Co., Richmond Hill, N. Y.....	316-950-500
WBAI	Purdue University, West Lafayette, Ind.....	283-1060-250
WBAD	Sterling Electric Co., Minneapolis, Minn.....	360-833-100
WBAK	Penn. State Dept. of Police, Harrisburg, Pa....	400-750-500
WBAN	Wireless Phone Corp., Paterson, N. J.....	244-1230-100
WBAP	Wortham-Carter Pub. Co., Fort Worth, Tex....	476-630-1000
WBAY	Erner & Hopkins Co., Columbus, Ohio.....	423-710-500
WBAW	Marietta College, Marietta, Ohio.....	246-1220-250
WBAZ	American Tel. & Tel. Co., New York, N. Y.....	492-610-500
WBAX	Wilkes-Barre, Pa.....	254-1180-
WBBF	*Georgia School of Technology, Atlanta, Ga.....	270-1110-500
WBBG	Irving Vermilya, Mattapoisett, Mass.....	248-1210-500
WBBR	Peoples' Pulpit Ass'n, Rossville, N. Y.....	273-1100-500
WBR	Penn State Police, Butler, Pa.....	286-1050-250
WBT	Southern Radio Corp., Charlotte, N. C.....	360-833-250
WBU	City of Chicago, Chicago, Ill.....	286-1050-500
WBZ	Westinghouse Elec. & Mfg. Co., Springfield, Mass.	337-890-1000
WCAD	St. Lawrence University, Canton, N. Y.....	280-1070-250
WCAE	Kaufmann & Baer Co., Pittsburgh, Pa.....	461-650-500
WCAH	Entrekin Electric Co., Columbus, O.....	286-1050-100
WCAJ	*Nebraska Wesleyan Univ., Univ. Place, Neb....	280-1070-500
WCAL	St. Olaf College, Northfield, Minn.....	360-833-500
WCAP	Chesapeake & Potomac Tel. Co., Wash'gt'n, D. C.	469-640-500
WCAR	Alamo Radio Elec. Co., San Antonio, Texas....	360-833-100
WCAS	W. E. Dunwoody Ind. Inst., Minneapolis, Minn...	246-1220-100
WCAT	S. Dakota State Sch. of Mines, Rapid City, S. D.	240-1250-100
WCAU	Durham & Co., Philadelphia, Pa.....	286-1050-250
WCAX	*Burlington, Vt.....	261-1150-
WCAV	Milwaukee Civic Broad. Assn., Milwaukee Wis.	261-1150-250
WCBC	Univ. of Michigan, Ann Arbor, Mich.....	280-1070-200
WCBD	Wilbur G. Voliva, Zion, Ill.....	345-870-500
WCCO	Washburn-Crosby Co., Minneapolis, Minn.....	417-720-500
WCK	Stix, Baer & Fuller Dry Goods Co., St. Louis, Mo.	360-833-100
WCX	Detroit Free Press, Detroit, Mich.....	517-580-500
WDAE	Tampa Daily Times, Tampa, Fla.....	360-833-250
WDAF	Kansas City Star, Kansas City, Mo.....	411-730-500
WDAG	J. Laurance Martin, Amarillo, Tex.....	263-1140-100
WDAR	Trinity Methodist Church, El Paso, Texas.....	268-1120-100
WDAU	Lit Brothers, Philadelphia, Pa.....	395-760-500
WDAX	Sloum & Kilburn, New Bedford, Mass.....	360-833-100
WDBH	First National Bank, Centerville, Iowa.....	360-833-100
WDBR	Worcester, Mass.....	268-1120-100
WEAF	Tremont Temple Baptist Church, Boston, Mass...	256-1170-100
WEAH	American Tel. & Tel. Co., New York, N. Y.....	492-610-500
WEAI	Wichita Board of Trade, Wichita, Kas.....	280-1070-100
WEAJ	Cornell University, Ithaca, N. Y.....	286-1050-500
WEAM	University of S. Dakota, Vermillion, S. Dak...	283-1060-200
WEAN	Borough of N. Plainfield, N. Plainfield, N. J...	286-1050-150
WEAO	Shepard Co., Providence, R. I.....	273-1100-100
WEAP	Ohio State University, Columbus, Ohio.....	294-1020-500
WEAS	Mobile Radio Co., Mobile, Ala.....	360-833-100
WEAU	Hecht Co., Washington, D. C.....	360-833-100
WEAY	Davidson Bros. Co., Sioux City, Iowa.....	275-1090-100
WEB	Iris Theatre, Houston, Texas.....	360-833-500
WEBH	Benwood Co., St. Louis, Mo.....	273-1100-100
WEBJ	Edgewood Beach Hotel Co., Chicago, Ill.....	273-1100-
WEBL	Third Avenue Rv. Co., New York, N. Y.....	273-1100-500
WEBW	R. C. A. United States (portable).....	226-1330-100
WEEL	*Beloit College, Beloit, Wis.....	283-1060-500
WEV	Edison Elec. Ill'm'n't'g Co., Boston, Mass....	303-990-500
WEW	Hurlbert-Still Electric Co., Houston, Texas...	263-1140-100
WFAA	St. Louis University, St. Louis, Mo.....	280-1070-100
WFAN	Dallas News & Dallas Journal, Dallas, Tex....	476-630-500
WFAP	Hutchinson Elec. Service Co., Hutchinson, Minn.	286-1050-100
WFBG	Univ. of Nebraska, Dept. of E. Eng., Lincoln, Neb.	725-1090-250
WFBH	William F. Gable Co., Altoona, Pa.....	261-1150-100
WFBK	Concourse Radio Corp., New York, N. Y.....	273-1100-500
WFBM	Galvin Radio Supply Co., Camden, N. J.....	236-1270-100
WFBN	*Dartmouth College, Hanover, N. H.....	256-1170-100
WFBP	*Onondaga Hotel, Syracuse, N. Y.....	286-1050-100
WFBW	*Merchants Heat & Light Co., Indianapolis, Ind.	268-1120-250
WFBZ	*Radio Sales & Service Co., Bridgewater, Mass...	226-1330-200
WFBZ	*5th Infantry, Maryland N. G., Baltimore, Md...	254-1180-100
WFBW	Ainsworth-Gates Radio Co., Cincinnati, Ohio...	309-970-750

	W.L. K.C. W.P.
WFI	Strawbridge & Clothier, Philadelphia, Pa.....395- 760- 500
WGAQ	*Youree Hotel, 406 Market St., Shreveport, La...360- 833- 100
WGAY	Northwestern Radio Co., Madison, Wis.....360- 833- 100
WGAZ	South Bend Tribune, South Bend, Ind.....275-1090- 250
WGBS	*Gimbel Brothers, New York, N. Y.....316- 950-1000
WGI	Am. Radio & Res'ch Corp., Medf'd Hillside, Mass.360- 833- 100
WGL	Thomas F. J. Rowlett, Philadelphia, Pa.....360- 833- 250
WGN	Drake Hotel (Whitestone Co.), Chicago, Ill.....370- 810-1000
WGR	Federal Manufacturing Co., Buffalo, N. Y.....319- 940- 750
WGY	General Electric Co., Schenectady, N. Y.....380- 790-1000
WHA	*University of Wisconsin, Madison, Wis.....275-1090- 500
WHAA	State University of Iowa, Iowa City, Iowa.....484- 620- 500
WHAD	Marquette University, Milwaukee, Wis.....280-1070- 100
WHAG	University of Cincinnati, Ohio.....222-1350- 200
WHAM	University of Rochester, Rochester, N. Y.....283-1060- 100
WHAS	Courier-Journal & Louisville Times, Louisville, Ky.400- 750- 500
WHAZ	Rensselaer Polytechnic Institute, Troy, N. Y.....380- 790- 500
WHB	Sweeney School Co., Kansas City, Mo.....411- 730- 500
WHK	Radiovox Co., Cleveland, Ohio.....283-1060- 100
WHN	George Schubel, New York, N. Y.....360- 833- 100
WHO	Des Moines, Ia. ....526- 570- 500
WIAC	Galveston Tribune, Galveston, Tex.....360- 833- 100
WIAD	Howard R. Miller, Philadelphia, Pa.....254-1180- 100
WIAK	Journal-Stockman Co., Omaha, Neb.....278-1080- 250
WIAR	Paducah Evening Sun, Paducah, Ky.....360- 833- 100
WIAS	*Home Electric Co., Burlington, Iowa.....283-1060- 100
WIK	K. & L. Electric Co., McKeesport, Pa.....234-1280- 100
WIP	Gimbel Brothers, Philadelphia, Pa.....508- 590- 500
WJAB	American Electric Co., Lincoln, Neb.....229-1310- 100
WJAD	Jackson's Radio Eng. Laboratories, Waco, Tex...360- 833- 150
WJAG	Norfolk Daily News, Norfolk, Neb.....283-1060- 250
WJAN	Peoria Star, Peoria, Ill.....280-1070- 100
WJAR	The Outlet Co., Providence, R. I.....360- 833- 500
WJAS	Pittsburgh Radio Supply House, Pittsburgh, Pa...286-1050- 500
WJAX	Union Trust Co., Cleveland, Ohio.....390- 770- 500
WJAZ	Chicago Radio Lab., Chicago, Ill. (portable)....268-1120- 100
WJH	Wm. P. Boyer Co., Washington, D. C.....273-1100- 100
WJJD	*Supreme Lodge Moose, Mooseheart, Ill.....278-1080- 500
WJY	R. C. A., New York, N. Y.....405- 740- 750
WJZ	Broadcast Central, New York, N. Y.....454- 660- 500
WKAA	H. F. Paar, Cedar Rapids, Iowa.....278-1080- 100
WKAF	W. S. Radio Supply Co., Wichita Falls, Tex.....360- 833- 100
WKAP	Dutee W. Flint, Cranston, R. I.....360- 833- 250
WKAQ	Radio Corp. of Porto Rico, San Juan, P. R.....360- 833- 500
WKAR	Michigan Agr. College, E. Lansing, Mich.....280-1070- 500
WKBF	D. W. Flint, Providence, R. I.....286- - 500
WKY	WKY Radio Shop, Oklahoma, Okla.....360- 833- 100
WLAL	Naylor Electrical Co., Tulsa, Okla.....360- 833- 100
WLAN	Putnam Hardware Co., Houlton, Me.....283-1060- 250
WLBL	Wisconsin Dept. of Markets, Stevens Pt., Wis...278-1080- 500
WLW	*Crosley Radio Corp., Cincinnati, O.....423- 710-1000
WMAC	Clive B. Meredith, Cazenovia, N. Y.....261-1150- 100
WMAF	Round Hills Radio Corp., Dartmouth, Mass.....360- 833- 500
WMAH	General Supply Co., Lincoln, Neb.....254-1180- 100
WMAK	*Norton Laboratories, Lockport, N. Y.....273-1100- 500
WMAQ	Chicago Daily News, Chicago, Ill.....448- 670- 500
WMAT	Paramount Radio Corp., Duluth, Minn.....266-1130- 250
WMAV	Alabama Polytechnic Institute, Auburn, Ala.....250-1200- 500
WMAY	Kingshighway Presbyterian Church, St. Louis, Mo.280-1070- 100
WMAZ	Mercer University, Macon, Ga.....261-1150- 100
WMC	"Commercial Appeal," Memphis, Tenn.....500- 600- 500
WMU	Doubleday-Hill Elec. Co., Washington, D. C.....261-1150- 100
WNAC	Shepard Stores, Boston, Mass.....278-1080- 100
WNAD	*University of Oklahoma, Norman, Okla.....254-1180- 100
WNAP	Wittenberg College, Springfield, Ohio.....231-1300- 100
WNAT	*Lenning Brothers Co., Philadelphia, Pa.....250-1200- 100
WNAX	Dakota Radio Apparatus Co., Yankton, S. D....244-1230- 100
WNYC	City of New York, New York, N. Y.....526- 570-1000
WNOAC	Pagan Organ Co., Lima, Ohio.....265-1130- 150

\*Additions and changes.

	W.L. K.C. W.P.
WOAI	Southern Equipment Co., San Antonio, Tex.....384- 780- 500
WOAL	William E. Woods, Webster Groves, Mo.....229-1310- 100
WOAN	Vaughn C'nserv't'ry of Music, Lawrenceb'rg, Tenn.360- 833- 200
WOAV	Penn. Nat'l Guard, 2d Bat, 112th Inf., Erie, Pa..242-1240- 100
WOAW	Woodmen of the World, Omaha, Neb.....526- 570- 500
WOAX	Franklyn J. Wolff, Trenton, N. J.....240-1250- 500
WOC	Palmer Sch. of Chiropractic, Davenport, Iowa...484- 620- 500
WOI	Iowa State College, Ames, Iowa.....360- 833- 500
WOO	John Wanamaker, Philadelphia, Pa.....508- 590- 500
WOQ	Western Radio Co., Kansas City, Mo.....360- 833- 500
WOR	L. Bamberger & Co., Newark, N. J.....405- 740- 500
WOS	Mo. State Marketing Bureau, Jefferson City, Mo.441- 680- 500
WPAB	Pennsylvania State College, State College, Pa....283-1060- 500
WPAC	Donaldson Radio Co., Okmulgee, Okla.....360- 333- 100
WPAH	Wisconsin Dept. of Markets, Waupaca, Wis....360- 833- 500
WPAJ	New Haven, Conn.....268-1120- 100
WPAK	North Dakota Agri. Col., Agri. College, N. D....283-1060- 200
WPAZ	John R. Koch (Dr.), Charleston, W. Va.....273-1100- 100
WQAA	Horace A. Beale, Jr., Parkesburg, Pa.....360- 833- 500
WQAC	E. B. Gish, Amarillo, Tex.....234-1280- 100
WQAM	Electrical Equipment Co., Miami, Fla.....283-1060- 100
WQAN	Scranton Times, Scranton, Pa.....280-1070- 100
WQAO	Calvary Baptist Church, New York, N. Y.....360- 833- 100
WQAQ	Abilene Daily Reporter, Abilene, Tex.....360- 833- 100
WQAS	Prince-Walter Co., Lowell, Mass.....265-1130- 100
WQAX	Radio Equipment Co., Peoria, Ill.....248-1210- 100
WQJ	Calumet Rainbo Broadcasting Co., Chicago, Ill...448- 670- 500
WRBC	Immanuel Lutheran Church, Valparaiso, Ind.....278-1080- 500
WRK	Doren Bros. Electric Co., Hamilton, Ohio.....360- 833- 200
WRAL	No. States Power Co., St. Croix Falls, Wis.....248-1210- 100
WRAM	Lombard College, Galesburg, Ill.....244-1230- 250
WRAV	Antioch College, Yellow Springs, Ohio.....242-1240- 100
WRAX	Flexion's Garage, Gloucester City, N. J.....268-1120- 100
WRC	Radio Corp. of America, Washington, D. C.....469- 640- 500
WREO	*Reo Motor Car Co., Lansing, Mich.....288-1040- 500
WRK	Doren Bros. Electric Co., Hamilton, Ohio.....360- 833- 200
WRL	Union College, Schenectady, N. Y.....360- 833- 500
WRM	*University of Illinois, Urbana, Ill.....273-1100- 500
WRW	Tarrytown Radio Research Lab., Tarrytown, N. Y.273-1100- 500
WSAB	*State Teachers College, Cape Girardeau, Mo....275-1090- 100
WSAC	Clemson Agri. Col., Clemson College, S. C.....360- 833- 500
WSAD	J. A. Foster Co., Providence, R. I.....261-1150- 100
WSAH	A. G. Leonard, Jr., Chicago, Ill.....248-1210- 500
WSAI	U. S. Playing Card Co., Cincinnati Ohio.....309- 970- 500
WSAJ	Grove City College, Grove City, Pa.....360- 833- 250
WSAP	Seventh Day Adventist Church, New York, N. Y..263-1140- 250
WSAR	Doughty & Welch Elec. Co., Fall River, Mass...254- - - - -
WSAV	Clifford W. Vick Radio Const. Co., Houston, Tex.360- 833- 100
WSAX	Chicago Radio Laboratory, Chicago, Ill.....448- 670-1000
WSB	Atlanta Journal, Atlanta, Ga.....428- 700- 500
WSOE	School of Eng. of Milwaukee, Milwaukee, Wis...246-1220- 100
WSY	Alabama Power Co., Birmingham, Ala.....360- 833- 500
WTAB	Fall River Daily Herald, Fall River, Mass.....248- - - - -
WTAC	Johnstown, Pa.....275-1090- 150
WTAM	The Willard Storage Battery Co., Cleveland, O...389- 770-1000
WTAN	Orndorff Radio Shop, Mattoon, Ill.....240-1250- 100
WTAQ	S. H. Van Gorden & Son, Osseo, Wis.....225-1330- 100
WTAR	Reliance Electric Co., Norfolk, Va.....280-1070- 100
WTAS	Charles E. Erbstein, Elgin, Ill., near.....286-1050- 500
WTAT	Edison Electric Illum. Co., Boston, Mass.....246-1220- 100
WTAW	College Station, Texas.....280-1070- 250
WTAY	Oak Leaves Broadcasting Station, Oak Park, Ill...283-1330- 500
WTG	Kansas State Agri. Col., Manhattan Ks.....360- 833- 500
WWAD	Wright & Wright, Inc., Philadelphia, Pa.....360- 833- 500
WWAE	*Alamo Ball Room, Joliet, Ill.....242-1240- 500
WWAO	*Michigan College of Mines, Houghton, Mich...244-1230- 250
WWJ	Detroit News, Detroit, Mich.....517- 580- 500
WWL	Loyola University, New Orleans, La.....268-1120- 100

Watch for Special Hook-up Number

# Radio Dealers!

---

---

Practically every Radio Fan who comes into your store will subscribe to RADIO PROGRESS, if you will keep a few copies on your counter. Those who won't subscribe will at least buy a single copy.

---

Why not ring up some of this business on your Cash Register? We will help you and will put you in touch with our distributor in your territory.

---

You'll be surprised when you discover how big an item this business will amount to in the course of a year. And you take absolutely no risk, nor do you have to invest a single cent of capital.

---

**GET ABOARD!** Send us your name and address to-day.

---

---

## *Radio Progress*

*8 Temple Street*

*Providence, R. I.*

*P. O. Box 728*



# GIBLIN

## RADIO APPARATUS

### The Giblin Broadcast Receiver

THE Giblin Radio Frequency Broadcast Receiver makes it possible to obtain radio entertainment without the necessity of erecting outside antenna wires or using a troublesome ground wire. A small, loop aerial placed near the set will pick up signals, which, though they have come long distances, and are weakened by hills, valleys, trees and buildings, will be clear and of great volume. Many families, living in apartments where it is undesirable or impossible to erect antenna wires, can now hear enjoyable, ever-changing programs through the day and evening by "listening-in" with a Giblin Radio Frequency Broadcast Receiver.

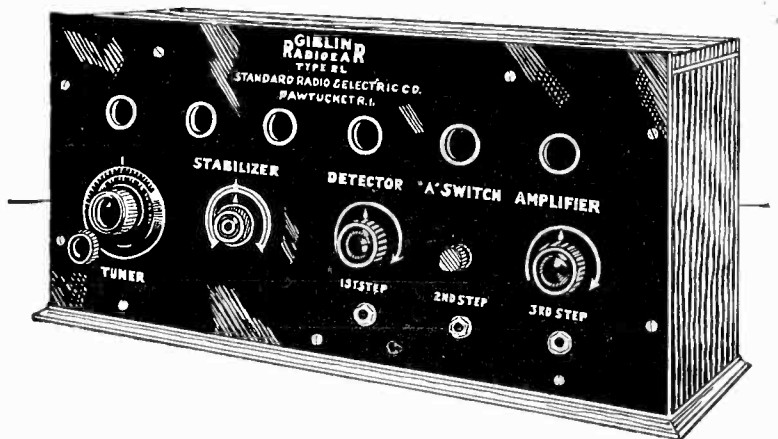

The set comprises two stages of radio frequency amplification, a detector and three stages of audio frequency amplification. The parts are mounted on a sub-base to which a Bakelite panel is attached. It is enclosed in a handsome solid mahogany cabinet.

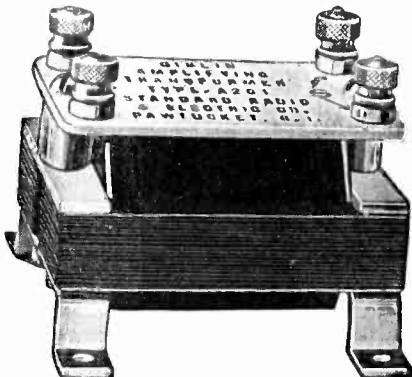

The Giblin Audio-Frequency Amplifying Transformer  
Price \$4.50



The Giblin Radio-Frequency Amplifying Transformer  
Price \$5.00

Buy Giblin Products from your dealer

*Write for descriptive circulars*

STANDARD RADIO & ELECTRIC CO.  
PAWTUCKET, RHODE ISLAND